

Physics C Science League Test
January, 2014

DIRECTIONS: Please PRINT your name, school, area, and which test you are taking on the scantron supplied.

Use $g = 10 \text{ m/s}^2$

- The coordinates of a particle in meters is given by $x(t) = 16t - 3.0t^3$, where the time t is in seconds. The particle is momentarily at rest at $t =$
 - 0.75 s
 - 1.3 s
 - 5.3 s
 - 7.3 s
 - 9.3 s
- A box is shot from ground level at 60° above horizontal with an initial speed V . At the highest point of its trajectory the box explodes horizontally into two unequal pieces. The mass of the smaller piece is $\frac{1}{4}$ of the mass of the larger piece. The smaller piece lands at exactly the launch point. What is the speed of the larger piece immediately after the explosion? Give the answer in terms of the initial speed V .

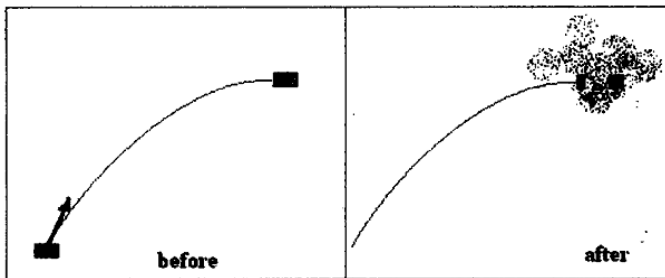

- $0.2 V$
- $0.25 V$
- $0.5 V$
- $0.75 V$
- V

- The airplane shown to the right is in level flight at an altitude of 0.50 km and a speed of 150 km/h. At what distance " d " should it release a heavy care package to hit a target at X? Take $g = 10 \text{ m/s}^2$

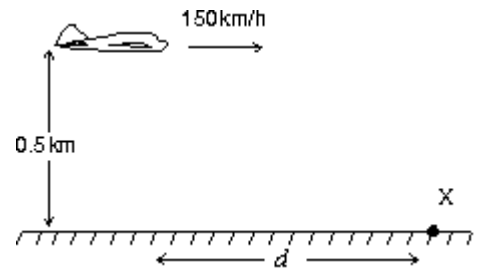

- 150 m
- 295 m
- 417 m
- 2550 m
- 15,000 m

- Use the diagram to the right. A ball is thrown horizontally from the top of a 20-m high hill. It strikes the ground at an angle of 45° . With what speed was it thrown?



- 14 m/s
- 20 m/s
- 28 m/s
- 32 m/s
- 40 m/s

- A cannon fires a projectile as shown below. The dashed line shows the trajectory in the absence of gravity. Points MNOP correspond to the position of the projectile at one second intervals. The lengths of X, Y, Z are

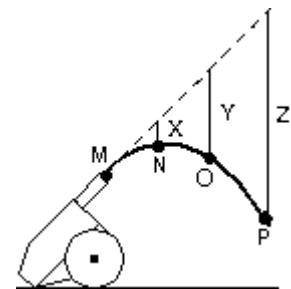

- 5 m, 10 m, 15 m
- 5 m, 20 m, 45 m
- 10 m, 40 m, 90 m
- 10 m, 20 m, 30 m
- 0.2 m, 0.8 m, 1.8 m

6. A girl wishes to row across a river in the shortest possible time. She can row at 2.0 m/s in still water and the river is flowing at 1.0 m/s. At what angle Θ should she point the front of her boat?

- a. 30° b. 45° c. 60° d. 63°
 e. 90°

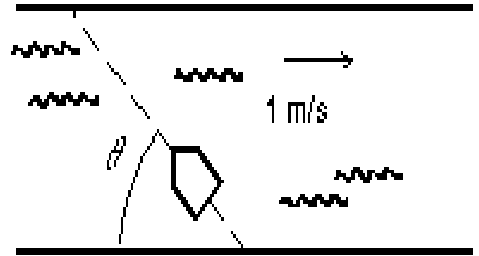

7. Two blocks are connected by a string to a pulley as shown below. Assuming that the string and pulley are massless, the magnitude of the acceleration of each block is

- a. 0.049 m/s^2 b. 0.020 m/s^2 c. 0.0098 m/s^2
 d. 0.54 m/s^2 e. 1 m/s^2

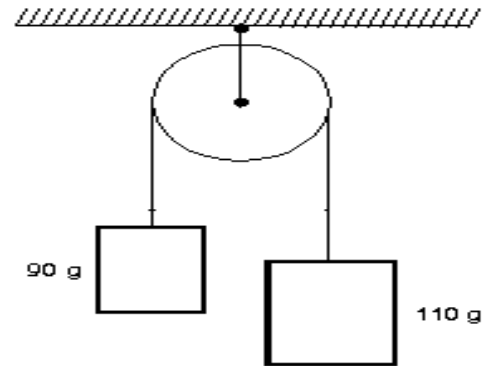

8. A man pulls a wooden box along a rough horizontal floor at constant speed by means of force P as shown below. In the diagram, f is the magnitude of the friction force, N is the magnitude of the normal force and F_g is the magnitude of the force of gravity. Which of the following must be true?

- a. $P = f$ and $N = F_g$
 b. $P = f$ and $N > F_g$
 c. $P > f$ and $N < F_g$
 d. $P > f$ and $N = F_g$
 e. *None of the above*

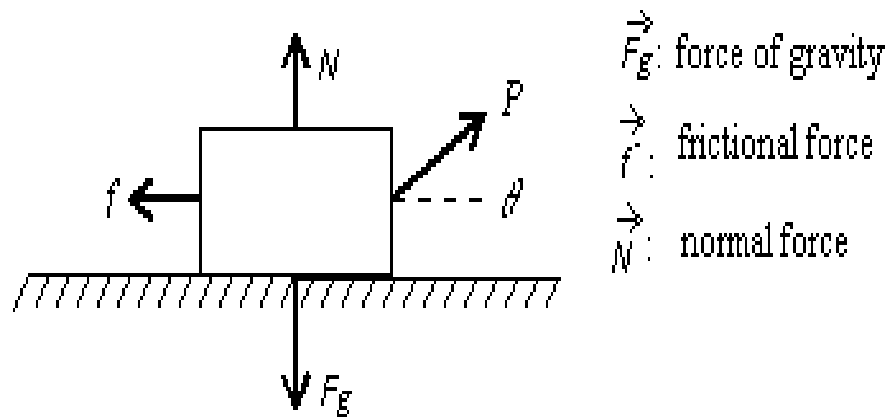

For questions 9 and 10 consider the following:

A block of mass m is dropped straight down into a pond. Its initial speed in the water is v_0 and the drag force in the water is proportional to its speed at any time during the plunge with a proportionality coefficient b .

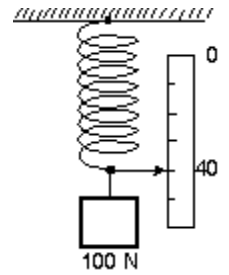

9. What is the terminal velocity of the stone?
 a. mg b. $3m/b$ c. $3b/m$ d. mgb e. mg/b

10. Assuming the stone's initial speed is greater than its terminal speed, which of the following graphs correctly represents the speed of the stone as a function of time?

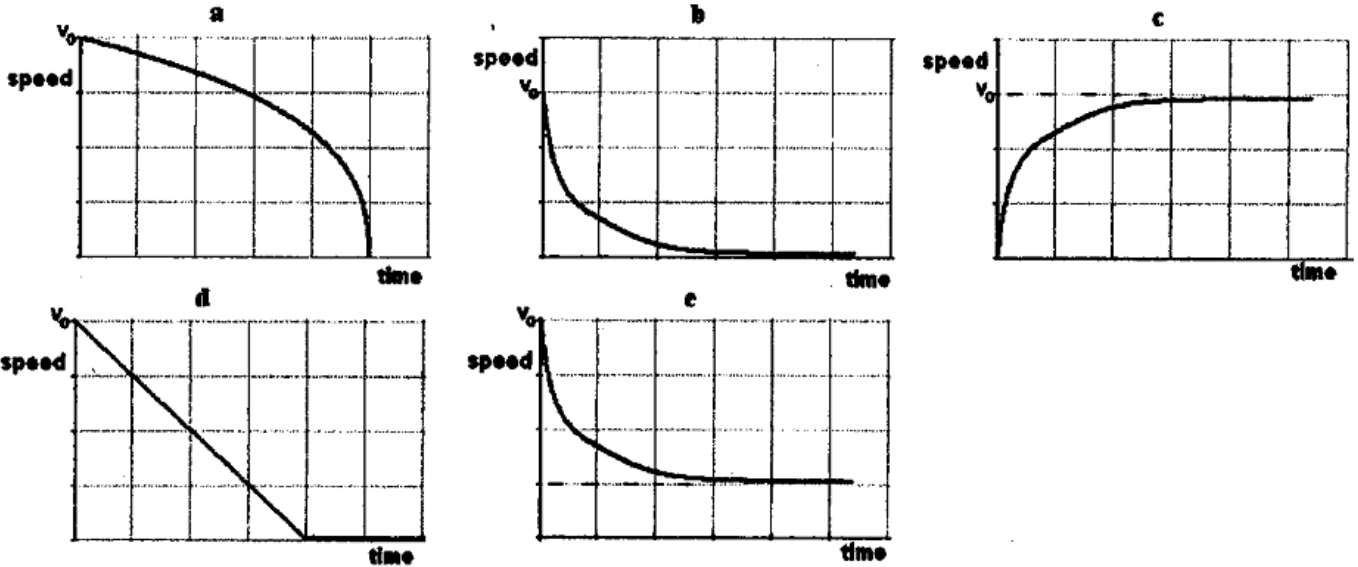

11. Block A, with a mass of 10 kg, rests on a 30° incline. The coefficient of kinetic friction is 0.20. The attached string is parallel to the incline and passes over a massless, frictionless pulley at the top. Block B, with a mass of 3.0 kg, is attached to the hanging end of the string as shown below. The acceleration of B is:

- a. 0.20 m/s^2 , up
 b. 0.20 m/s^2 , down
 c. 2.8 m/s^2 , up
 d. 2.8 m/s^2 , down
 e. 0

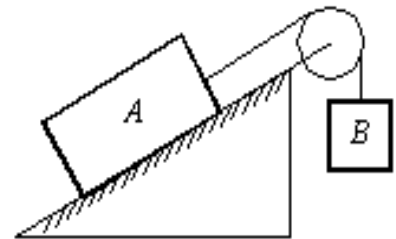

12. The iron ball shown below is being swung in a vertical circle at the end of a 0.7-m string. How slowly can the ball go through its top position without having the string go slack?

- a. 1.3 m/s b. 2.6 m/s c. 3.9 m/s d. 6.9 m/s e. 9.8 m/s

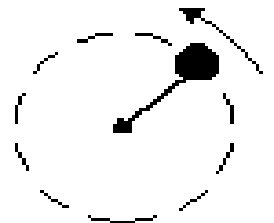

13. An ideal spring, with a pointer attached to its end, hangs next to a scale. With a 100-N weight attached, the pointer indicates "40" on the scale as shown. Using a 200-N weight instead results in "60" on the scale. Using an unknown weight X instead results in "30" on the scale. The weight of X is:

- a. 10 N b. 20 N c. 30 N d. 40 N e. 50 N

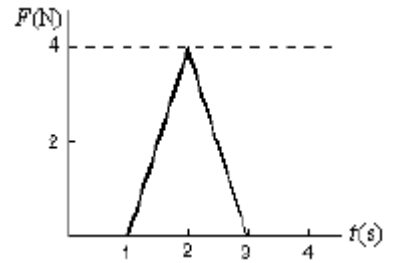

14. When a certain spring is stretched a distance A , it exerts a restoring force $F = ax + bx^2$, where a and b are constants. The work done in stretching this spring from $x = 0$ to $x = L$ is:

- a. $aL^2 + 2bLx^3$
 b. $aL + 2bLx^2$
 c. $a + bL$
 d. bL
 e. $1/2 aL^2 + 1/3 bL^3$

15. A 0.20 kg particle moves along the x-axis under the influence of a stationary object. The potential energy is given by

$$U(x) = (8.0 \text{ J/m}^2) x^2 + (2.0 \text{ J/m}^4) x^4$$

If the particle has a speed of 5.0 m/s when it is at $x = 1.0$ m, its speed when it is at the origin is

- a. 0 b. 2.5 m/s c. 5.7 m/s d. 7.9 m/s e. 11 m/s

16. A toy cork gun contains a spring whose spring constant is 10.0 N/m. The spring is compressed 5.00 cm and then used to propel a 6.00-g cork. The cork, however, sticks to the spring for 1.00 cm beyond its unstretched length before separation occurs. The muzzle velocity of this cork is

- a. 1.02 m/s b. 1.41 m/s c. 2.00 m/s d. 2.04 m/s e. 4.00 m/s

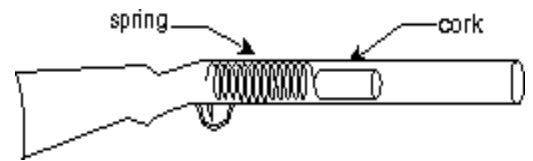

17. A small object of mass m , on the end of a light cord, is held horizontally at a distance r from a fixed support as shown below. The object is then released. What is the tension in the cord when the object is at the lowest point of its swing?

- a. $mg/2$ b. mg c. $2 mg$ d. $3 mg$ e. mgr

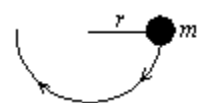

18. A small object of mass m starts at rest at the position shown and slides along the frictionless loop-the-loop track of radius R . What is the smallest value of y such that the object will slide without losing contact with the track?

- a. $R/4$ b. $R/2$ c. R d. $2R$ e. zero

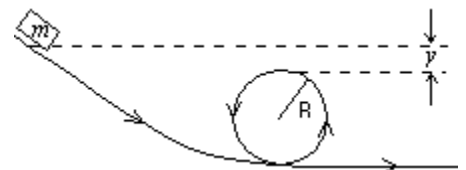

19. A 5-kg object can move along the x-axis. It is subjected to a force F in the positive x-direction; a graph of F as a function of time t is shown to the right. Over the time the force is applied the change in the velocity of the object is

- a. 0.8 m/s b. 1.1 m/s c. 1.6 m/s d. 2.3 m/s e. 4.0 m/s

20. A 3-g bullet is fired horizontally into a 10-kg block of wood suspended by a rope from the ceiling. The block swings in an arc, rising 3 mm above its lowest position. The velocity of the bullet was

- a. Unknown since the heat generated in the collision was not given
- b. 8×10^2 m/s
- c. 24.0 m/s
- d. 8.0 m/s
- e. 2.4×10^4 m/s

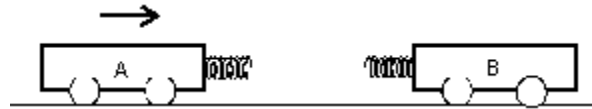
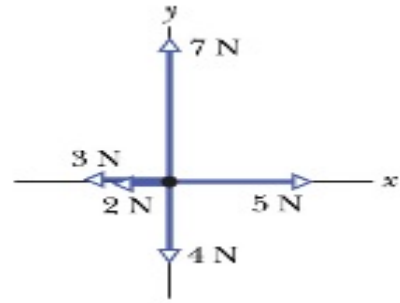

21. Two carts, A and B, having spring bumpers, collide as shown above. Cart A has a mass of 2 kg and is initially moving to the right. Cart B has a mass of 3 kg and is initially stationary. When the separation between the carts is a minimum

- a. Cart B is still at rest
- b. Cart A has come to rest
- c. The carts have the same momentum
- d. The carts have the same kinetic energy
- e. The kinetic energy of the system is at a minimum

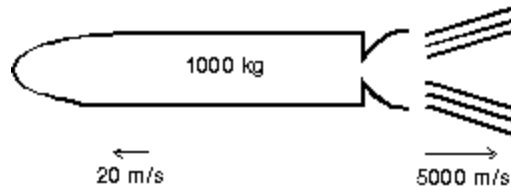

22. A 1,000 kg space probe is motionless in space. To start moving, its main engine is fired for 5.0 s during which time it ejects exhaust gases at 5,000 m/s. At the end of this process it is moving at 20 m/s. The approximate mass of the ejected gas is

- a. 0.8 kg
- b. 4 kg
- c. 5 kg
- d. 20 kg
- e. 25 kg

Use the free body diagram to the right for questions 23 and 24:

23. Which $V_x(t)$ graph best corresponds to the free body diagram?

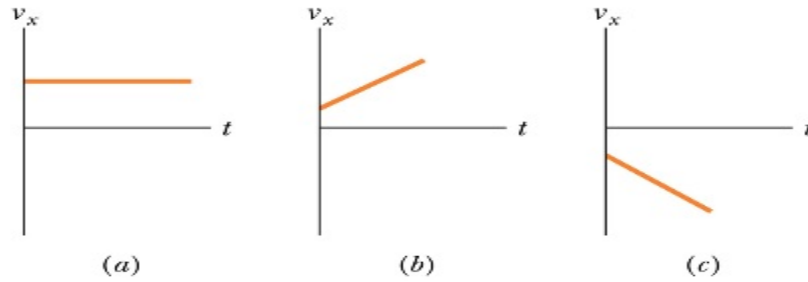

24. Which $V_y(t)$ graph best corresponds to the free body diagram?

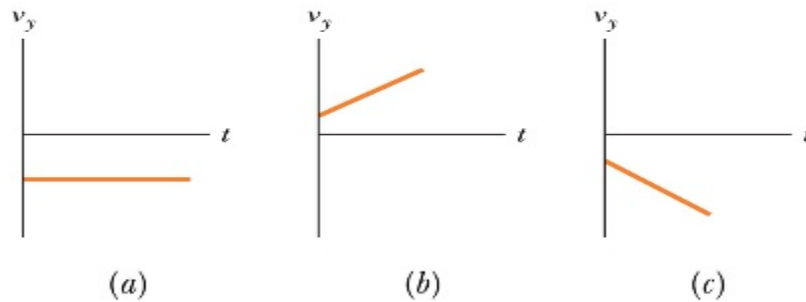

25. Block 1 with mass “ m ” slides across a frictionless floor and then undergoes an elastic collision with a stationary block 2 with mass “ m ”. In the plot below of position x versus time t for block 1, x_c is the position and t_c is the time at which the collision occurs. Along which of the dashed lines will the plot be continued after the collision?

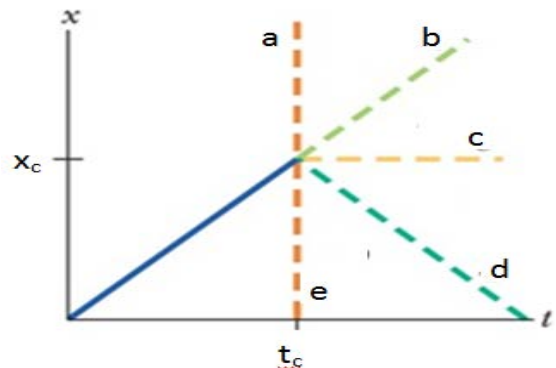

1 -B	6 -E	11 -A	16 -C	21 -E
2 -D	7 -E	12 -B	17 -D	22 -B
3 -C	8 -C	13 -E	18 -B	23 -A
4 -B	9 -E	14 -E	19 -A	24 -B
5 -B	10 -E	15 -E	20 -B	25 -C

NJSL Physics C Exam
February 13, 2014

DIRECTIONS: Please PRINT your name, school, area, and which test you are taking on the Scantron supplied. For each statement or question, completely fill in the appropriate space on the answer sheet. Use the letter preceding the word or phrase or sketch which best completes the statement or answers the question. Unless stated otherwise assume ideal conditions including no friction. Sketches are not to scale. Assume $g = -9.8\text{m/s}^2$ and the following moments of inertia:

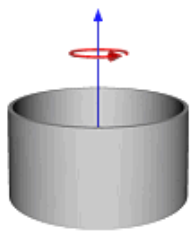

thin hoop or ring of radius R & mass M :

$$MR^2$$

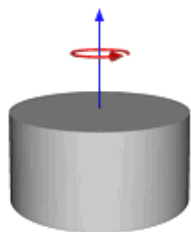

solid cylinder or disc of radius R and mass M :

$$\frac{1}{2}MR^2$$

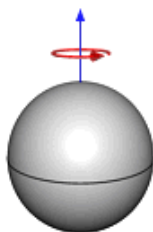

solid sphere of radius R and mass M :

$$\frac{2}{5}MR^2$$

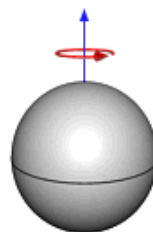

thin-walled hollow sphere of radius R & mass M :

$$\frac{2}{3}MR^2$$

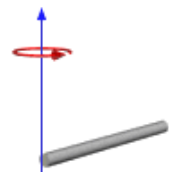

slender rod of length L and mass M , spinning around end:

$$\frac{1}{3}ML^2$$

A uniform sphere, which has a mass of $M=5m$ and a radius R , rotates without friction about a fixed axis through its center of mass. A string is wrapped around its circumference and is attached to a mass m which is allowed to fall to the floor a distance h below. The string does not slip on the surface of the sphere.

1. What is the tension in the cord while the mass m is falling to the floor below?
A. $\frac{2}{3}mg$ B. $\frac{1}{5}mg$ C. $\frac{2}{5}mg$ D. $\frac{1}{7}mg$ E. $\frac{1}{4}mg$

2. What will be the angular velocity of the sphere at the moment the mass m reaches the floor?

A. $\sqrt{\frac{gh}{R}}$ B. $\sqrt{\frac{2gh}{5R^2}}$ C. $\sqrt{\frac{3gh}{R^2}}$ D. $\sqrt{\frac{2gh}{3R^2}}$ E. $\sqrt{\frac{gh}{R^2}}$

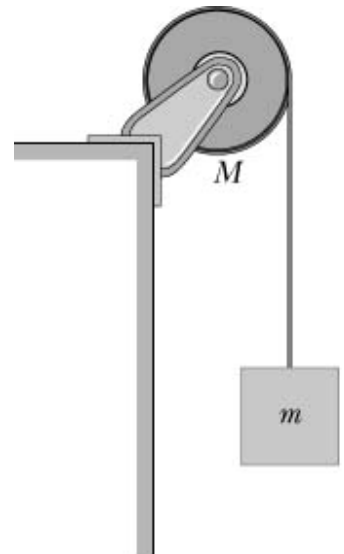

3. What is the angular momentum of this system at the moment the mass m reaches the floor?

A. $mR\sqrt{\frac{4}{3}gh}$ B. $mR\sqrt{6gh}$ C. $mR\sqrt{\frac{2}{3}gh}$ D. $2mR\sqrt{3gh}$ E. $mR\sqrt{\frac{2}{5}gh}$

A mass m is attached to the wall by a spring which has a constant k and a length L . When the spring is at its equilibrium length L the mass is given an initial velocity v_0 resulting in the mass oscillating with an amplitude A . The first spring is then replaced by a second spring identical in every respect to the first spring except that it is $1/3^{\text{rd}}$ as long. The mass m is then given the same initial velocity v_0 as in the first case.

4. What is the spring constant k_2 of the second spring?
 A. $6k$ B. $2k$ C. $3/k$ D. $k/6$ E. $3k$
5. What will be the maximum amplitude of the resulting oscillation?
 A. $A/\sqrt{3}$ B. $\sqrt{2}A$ C. $3A$ D. $\sqrt{3}A$ E. $A/\sqrt{6}$

6. Three equal mass satellites A, B, and C are in coplanar orbits around a planet as shown in the figure. The magnitudes of the angular momenta of the satellites as measured about the planet are L_A , L_B , and L_C . Which of the following statements correctly relates the angular momenta of these three satellites?

- A. $L_C < L_A < L_B$
 B. $L_C < L_B < L_A$
 C. $L_B < L_C < L_A$
 D. $L_A < L_B < L_C$
 E. $L_A = L_B = L_C$

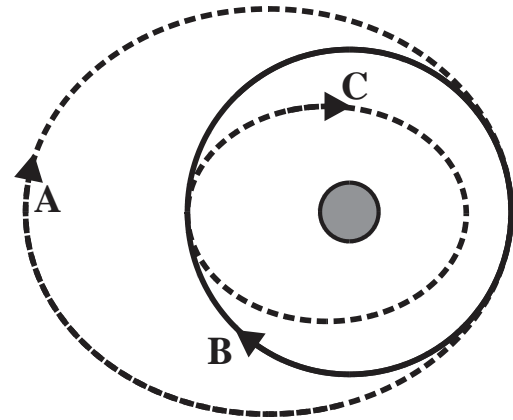

A metal plate of uniform mass density has a mass M , a length $2L$ and a width L as shown to the left. The plate is pivoted about an axis perpendicular to the plate and through point C. The bottom left corner of the plate is displaced a small distance A from equilibrium and is released resulting in the plate oscillating about point C.

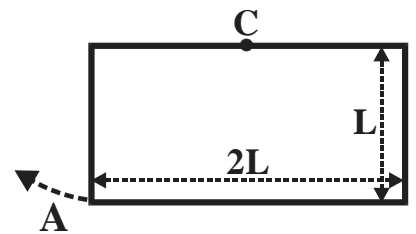

7. What is the moment of inertia of this plate about an axis perpendicular to the plate and through point C?
 A. $\frac{1}{3} \cdot M \cdot L^2$ B. $\frac{2}{3} \cdot M \cdot L^2$ C. $\frac{3}{5} \cdot M \cdot L^2$ D. $\frac{1}{12} \cdot M \cdot L^2$ E. $\frac{1}{3} \cdot M \cdot L^2$
8. What will be the period of oscillation about point C?
 A. $2\pi \cdot \sqrt{\frac{L}{g}}$ B. $2\pi \cdot \sqrt{\frac{3L}{g}}$ C. $2\pi \cdot \sqrt{\frac{L}{6g}}$ D. $4\pi \cdot \sqrt{\frac{L}{3g}}$ E. $2\pi \cdot \sqrt{\frac{3L}{2g}}$

A mass M is attached to one end of a spring, which has a spring constant k , while the other end of the spring is attached to a fixed vertical surface as shown to the right. A second mass of $3M$ is moving towards the left with a velocity v_0 along a frictionless horizontal surface when it collides with and sticks to the first mass after which the two masses, still attached to the spring, oscillate back and forth.



9. What will be the maximum compression of the spring?
 A. $\frac{1}{3} v_0 \cdot \sqrt{\frac{3M}{2k}}$ B. $\frac{2}{3} v_0 \cdot \sqrt{\frac{4M}{k}}$ C. $\frac{1}{6} v_0 \cdot \sqrt{\frac{M}{3k}}$ D. $\frac{3}{2} v_0 \cdot \sqrt{\frac{M}{k}}$ E. $\frac{3}{4} v_0 \cdot \sqrt{\frac{5M}{2k}}$

10. What will be the maximum acceleration of the masses after the initial collision?

- A. $\frac{1}{3} v_0 \cdot \sqrt{\frac{3k}{2M}}$ B. $\frac{3}{8} v_0 \cdot \sqrt{\frac{k}{M}}$ C. $\frac{3}{4} v_0 \cdot \sqrt{\frac{2k}{M}}$ D. $\frac{5}{9} v_0 \cdot \sqrt{\frac{3k}{2M}}$ E. $\frac{2}{3} v_0 \cdot \sqrt{\frac{k}{3M}}$

A block, which has a mass M , a height H and a width W , is sitting on a horizontal board which has a coefficient of static friction of μ_s . The right end of the board is lifted until the block topples over.

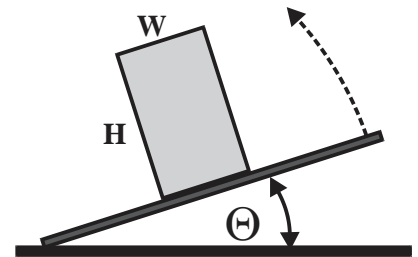

11. What is the angle Θ between the board and the horizontal at the moment the block begins to topple?

- A. $\mu_s \cdot \sin^{-1}(H/W)$ B. $\cos^{-1}(2H/W)$ C. $\tan^{-1}(W/H)$
 D. $\tan^{-1}(H/W)$ E. $\mu_s \cdot \cos^{-1}(H/2W)$

A uniform disk, which has a mass m and a radius R , is rotating with an angular velocity ω_0 when it is gently placed on a horizontal surface which has a coefficient of kinetic friction μ_k . After being released the sphere is initially slipping but eventually starts to roll without slipping.

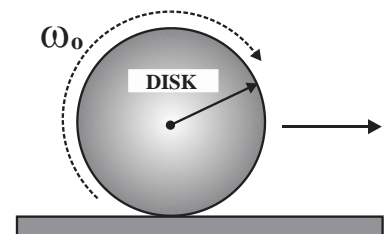

12. What will be the angular acceleration of the sphere immediately after being released on the horizontal surface?

- A. $\frac{3}{2} \cdot g \cdot \mu_k / R$ B. $-2 \cdot g \cdot \mu_k / R$ C. $-\frac{3}{2} \cdot g \cdot \mu_k / R$ D. $\frac{7}{2} \cdot g \cdot \mu_k / R$ E. $-\frac{5}{23} \cdot g \cdot \mu_k / R$

13. What will be the final angular velocity of the disk when the disk starts to roll without slipping?

- A. $\omega_0/2$ B. $\omega_0/6$ C. $\omega_0/4$ D. $\omega_0/3$ E. $\omega_0/9$

14. A simple pendulum consists of a 3.0 kg mass hanging on the end of a 2.0 m string. The mass is pulled back 10.0 cm and is released. After 30 complete cycles the maximum displacement of the mass has decreased to 5.0 cm.

What is the time constant for this pendulum?

- A. 12 sec B. 22 sec C. 61 sec D. 69 sec E. 74 sec

Two masses, $4m$ and m , are connected together by a string which has a length L and are rotating about their common center of mass with an angular velocity ω_0 .

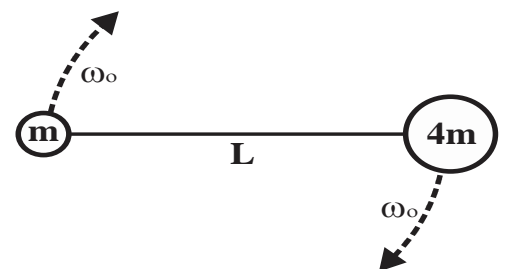

15. How far from the smaller mass m will the center of mass of this system be located?

- A. $L/2$ B. $2L/3$ C. $4L/5$ D. $3L/4$ E. $7L/8$

16. What is the moment of inertia of this system?

- A. $\frac{4}{5} \cdot mL^2$ B. $\frac{3}{4} \cdot mL^2$ C. $\frac{3}{5} \cdot mL^2$ D. $\frac{1}{3} \cdot mL^2$ E. $\frac{5}{3} \cdot mL^2$

A force is then applied to the string shortening the string until its length is reduced to $L/2$.

17. What will be the new angular velocity of the system?

- A. $\frac{3}{4} \cdot \omega_0$ B. $\frac{16}{5} \cdot \omega_0$ C. $\frac{8}{3} \cdot \omega_0$ D. $4 \cdot \omega_0$ E. $5 \cdot \omega_0$

In a different experiment a ball with a mass m is being spun in a horizontal circle at the end of a string of length L . The string is then shortened until it then has a length $L/3$.

18. How much work must be done in the process of shortening the string?

- A. $\frac{3}{2} \cdot mL^2 \omega_0^2$ B. $\frac{9}{2} \cdot mL^2 \omega_0^2$ C. $4 \cdot mL^2 \omega_0^2$ D. $3 \cdot mL^2 \omega_0^2$ E. $\frac{5}{8} \cdot mL^2 \omega_0^2$

You are sitting at rest on a chair capable of rotating freely while holding a bicycle wheel shaped like a ring. The ring has a radius r and a mass m and is rotating counterclockwise with an angular velocity ω_0 as shown to the right. Your mass (including the wheel and chair) is $8m$ and your radius of gyration is $2r$. Suddenly, during a time period Δt you invert the wheel so that the wheel is now rotating clockwise without any change in speed as shown below.



19. What was the rotational impulse delivered to the wheel as the wheel was being inverted?

- A. $\frac{1}{2} \cdot mr^2 \omega_0$ B. $4 \cdot mR^2 \omega_0$ C. $2 \cdot mr^2 \omega_0$
 D. $-3 \cdot mR^2 \omega_0$ E. $-2 \cdot mr^2 \omega_0$

20. What will be the direction of your angular velocity after inverting the wheel?

- A. left B. right C. down D. up
 E. into the page

21. What will be the magnitude of your angular velocity after inverting the wheel?

- A. $\omega_0/6$ B. $\omega_0/8$ C. $\omega_0/4$ D. $\omega_0/16$ E. $3\omega_0/4$

22. Which of the following descriptions about the angular momentum and kinetic energy of this system is correct as the wheel is being inverted?

Angular Momentum Kinetic Energy

- | | |
|--------------|-----------|
| A. increases | constant |
| B. decreases | increases |
| C. constant | constant |
| D. increases | decreases |
| E. constant | increases |

23. A satellite moves in a stable circular orbit with speed v_0 at a distance R from the center of a planet. For this satellite to move in a stable circular orbit a distance $3 \cdot R$ from the center of the planet, the speed of the satellite must be?

- A. $v_0/\sqrt{3}$ B. $v_0/\sqrt{2}$ C. $2v_0/\sqrt{3}$ D. $3v_0/\sqrt{2}$ E. $3v_0/\sqrt{3}$

24. A satellite, which has a mass m , is moving in an elliptical orbit around a planet P , as shown to the right, with r_a and r_b being its closest and farthest distances, respectively, from the center of the planet where $r_b = 4 \cdot r_a$. At point A the kinetic energy of the satellite is KE . What is the kinetic energy of the satellite at point B in the orbit?

- A. $KE/2$ B. $4 \cdot KE$ C. $KE/16$ D. $KE/4$ E. $8 \cdot KE$

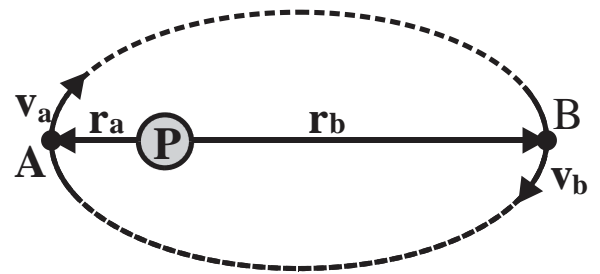

A tangential force F is applied to the edge of a solid sphere which is free to rotate about an axis through its center of mass. The sphere has a mass of 20.0 kg and a radius of 50

cm. As a result the sphere undergoes an angular displacement given by:

$$\Theta = 12t^2 + 6t - 8$$

25. What is the magnitude of the applied force F ?

- A. 96N B. 72N C. 69N D. 24N
14N

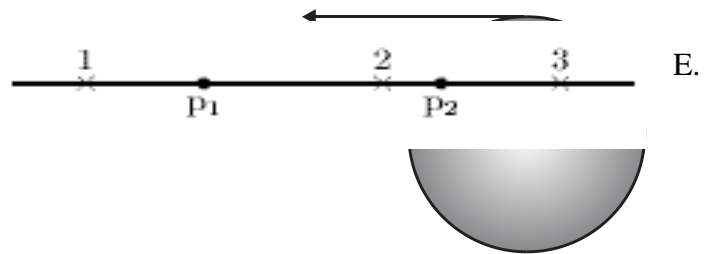

Physics C Answer Key: Orchid Test
Feb 13, 2014

1 -A	6 -B	11 -C	16 -A	21 -D
2 -D	7 -B	12 -B	17 -D	22 -E
3 -B	8 -D	13 -D	18 -C	23 -A
4 -E	9 -D	14 -C	19 -E	24 -C
5 -A	10 -B	15 -C	20 -D	25 -A

Physics C Science League Test
March, 2014

DIRECTIONS: Please PRINT your name, school, area, and which test you are taking on the scantron supplied.

$$k = 9.0 \times 10^9 \text{ Nm}^2/\text{C}^2 \quad \epsilon_0 = 8.854 \times 10^{-12} \text{ F/m}$$

- Two identical conducting spheres A and B carry equal charge. They are separated by a distance much larger than their diameters. A third identical conducting sphere C is uncharged. Sphere C is first touched to A, then to B, and finally removed. As a result, the electrostatic force between A and B, which was originally F , becomes
 - $F/2$
 - $F/4$
 - $3F/8$
 - $F/16$
 - 0
- The figure below shows two charged particles on an axis. Where should a third charged particle be placed along the axis of the two charges and should it be positively or negatively charged, so that all three particles are then in equilibrium?
 - To the left of the two charged particles and negative
 - To the right of the two charged particles and negative
 - Between the two charged particles and positive
 - Between the two charged particles and negative
 - There is no point on the axis where any charged particle would produce equilibrium
- Two protons (p_1 and p_2) are on the x-axis as shown below. The directions of the electric field at points 1, 2, and 3 respectively are:

- $\leftarrow, \rightarrow, \leftarrow$
- $\rightarrow, \leftarrow, \rightarrow$
- $\leftarrow, \rightarrow, \rightarrow$
- $\leftarrow, \leftarrow, \leftarrow$
- $\leftarrow, \leftarrow, \rightarrow$



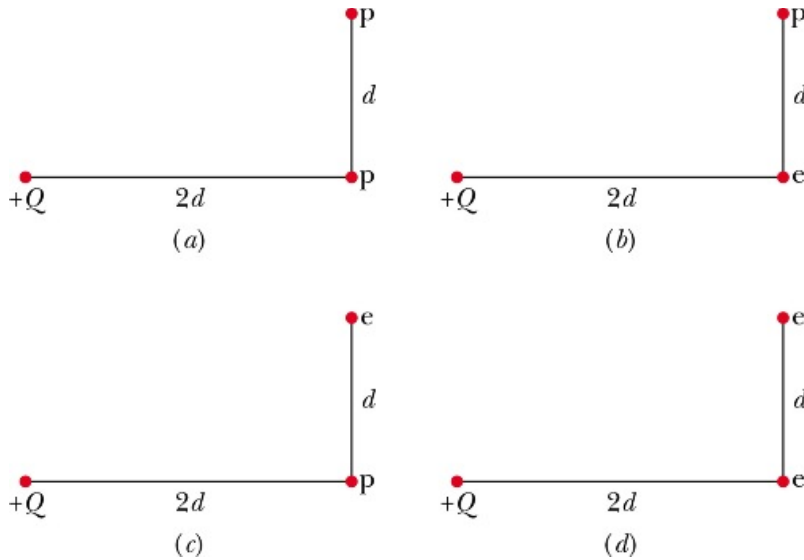

4. The figure above shows four arrangements of charged particles. Which of these arrangements has equal magnitudes of electrostatic force on the particle with charge $+Q$ from the p (proton) and/or e (electron) combination?
- $a=d$ and $b=c$
 - $a=b$ only
 - $b=c$ only
 - $c=d$ only
 - $a=c$ and $c=d$

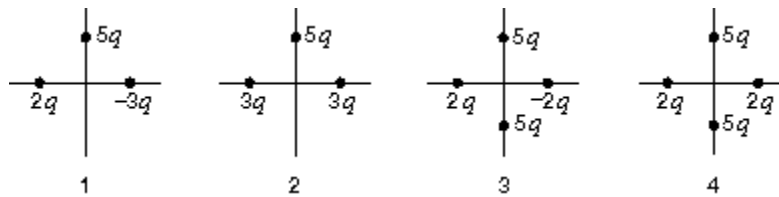

5. The diagrams above depict four different charge distributions. The charged particles are all the same distance from the origin. The electric field at the origin:
- is downward for situation 3
 - is zero for situation 4
 - is greatest for situation 2
 - is greatest for situation 3
 - is downward for situation 1

6. A point particle with charge q is at the center of a Gaussian surface in the form of a cube. The electric flux through any one face of the cube is:

- $\frac{q}{4\pi\epsilon_0}$
- $\frac{q}{4\epsilon_0}$
- $\frac{q}{\epsilon_0}$
- $\frac{q}{6\epsilon_0}$
- $\frac{q}{16\epsilon_0}$

7. A solid insulating sphere of radius R contains a positive charge that is distributed with a volume charge density that does not depend on angle but does increase linearly with distance from the sphere's center. Which of the graphs below correctly gives the magnitude E of the electric field as a function of the distance r from the center of the sphere?

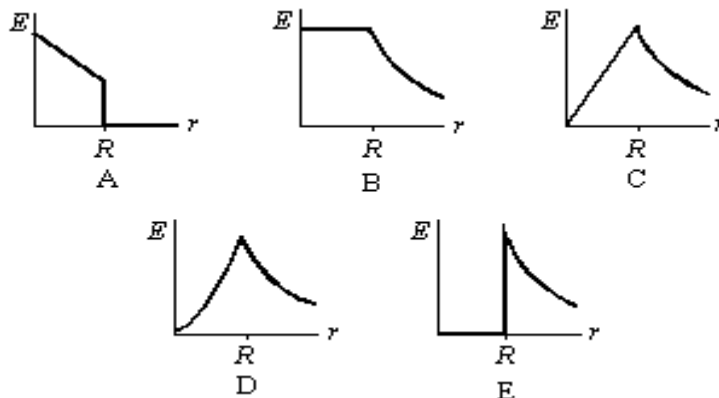

8. A charge Q is distributed uniformly throughout an insulating sphere of radius R . The magnitude of the electric field at a point $R/2$ from the center is
- a. $\frac{q}{4\pi\epsilon_0 R^2}$ b. $\frac{q}{\pi\epsilon_0 R^2}$ c. $\frac{3q}{4\pi\epsilon_0 R^2}$ d. $\frac{q}{8\pi\epsilon_0 R^2}$ e. $\frac{q}{16\pi\epsilon_0 R^2}$
9. The equivalent resistance between points 1 and 2 of the circuit shown to the side is:
- a. 2.5Ω b. 4.5Ω c. 5.5Ω
d. 6.5Ω e. 7.5Ω

10. The figure above shows four solid non-conducting spheres, each with charge Q uniformly distributed throughout its volume. The figure also shows a point P for each sphere, all at the same distance from the center of the sphere. At which point P is the Electric field least?

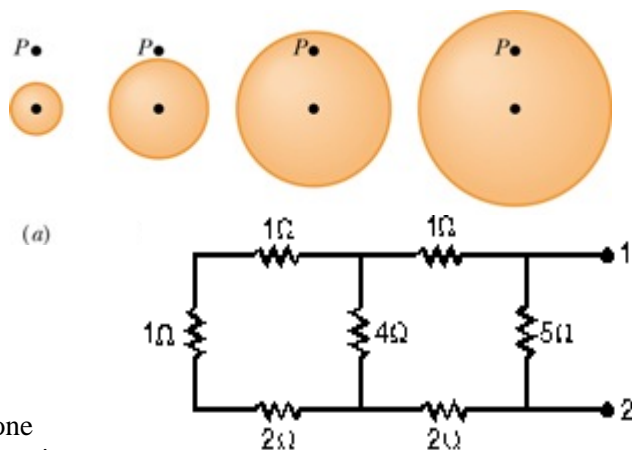

- a. The Electric field is least in situation (a).
b. The Electric field is least in situation (b).
c. The Electric field is least in situation (c).
d. The Electric field is least in situation (d).
e. The Electric field is the same at each point P .
11. If 500 J of work are required to carry a 40 C charge from one point to another, the potential difference between these two points is
- a. 12.5 V d. 0.08 V
b. 125 V e. It depends on the path.
c. 20,000 V
12. Positive charge is distributed uniformly throughout a non-conducting sphere. The highest electric potential occurs:
- a. at the surface d. just outside the surface
b. at the center e. far from the sphere
c. halfway between the center and the surface
13. A total charge of 7.0×10^{-8} C is uniformly distributed throughout a non-conducting sphere with a radius of 5.0 cm. The electric potential at the surface, relative to the potential far away, is about:
- a. -1.3×10^4 V d. -6.3×10^4 V
b. 1.3×10^4 V e. 0 V
c. 7.0×10^5 V

14. If the electric field is in the positive x direction and has a magnitude given by $E = Cx^2$, where C is a constant, with the potential at the origin = zero, then the electric potential is given by $V =$
- a. $-2Cx$
 - b. $2Cx$
 - c. $-1/3 Cx^3$
 - d. $1/3 Cx^3$
 - e. $3 Cx^3$

15. Eight identical spherical raindrops are each at a potential V , relative to the potential far away. They come together to make one spherical raindrop whose potential is:
- a. $8V$ b. $V/8$ c. $V/2$ d. $2V$ e. $4V$

16. As shown below, two particles with charges Q and $-Q$ are fixed at the vertices of an equilateral triangle with sides of length a . The work required to move a particle with a charge q from the other vertex to the center of the line joining the fixed charges is:

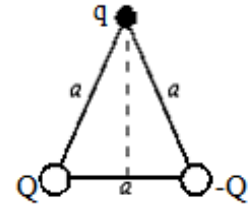

- a. 0 b. kQq/a c. kQq/a^2
d. $2kQq/a$ e. $\sqrt{2} kQq/a$

17. A particle with a charge of $5.5 \times 10^{-8} \text{ C}$ is 3.5 cm from a particle with a charge of $-2.3 \times 10^{-8} \text{ C}$. The potential energy of this two-particle system, relative to the potential energy at infinite separation is:
- a. $3.2 \times 10^{-4} \text{ J}$ b. $-3.2 \times 10^{-4} \text{ J}$ c. $3.6 \times 10^{-14} \text{ J}$ d. $-1.0 \times 10^{-13} \text{ J}$ e. 0 J

18. A 5 cm radius conducting sphere has a charge density of $2 \times 10^{-6} \text{ C/m}^2$ on its surface. Its electric potential, relative to the potential far away is:

- a. $2.2 \times 10^4 \text{ V}$ b. $1.1 \times 10^4 \text{ V}$ c. $2.3 \times 10^5 \text{ V}$ d. $3.6 \times 10^5 \text{ V}$ e. $7.2 \times 10^6 \text{ V}$

19. A conducting sphere has charge Q and its electric potential is V , relative to the potential far away. If the charge is doubled to $2Q$, the potential is

- a. V b. $2V$ c. $4V$ d. $V/2$ e. $V/4$

20. A parallel plate capacitor has a plate area of 0.2 m^2 and a plate separation of 0.1 mm . To obtain an Electric field of $2.0 \times 10^6 \text{ V/m}$ between the plates, the magnitude of the charge on each plate should be:

- a. $8.9 \times 10^{-7} \text{ C}$ b. $1.8 \times 10^{-6} \text{ C}$ c. $3.5 \times 10^{-6} \text{ C}$ d. $7.1 \times 10^{-6} \text{ C}$ e. $1.4 \times 10^{-5} \text{ C}$

21. A $2 \mu\text{F}$ and a $1 \mu\text{F}$ capacitor are connected in series and a potential difference is applied across the combination. The $2 \mu\text{F}$ capacitor has:

- a. half the potential difference of the $1 \mu\text{F}$ capacitor.
b. twice the potential difference of the $1 \mu\text{F}$ capacitor.
c. half the charge of the $1 \mu\text{F}$ capacitor.
d. twice the charge of the $1 \mu\text{F}$ capacitor.
e. The same potential difference as the $1 \mu\text{F}$ capacitor.

22. Capacitor C_1 is connected alone to a battery and charged until the magnitude of the charge on each plate is $4.0 \times 10^{-8} \text{ C}$. Then it is removed from the battery and connected to two other capacitors C_2 and C_3 , as shown below. The charge on the positive plate of C_1 is then $1.0 \times 10^{-8} \text{ C}$. The charges on the positive plates of C_2 and C_3 are:

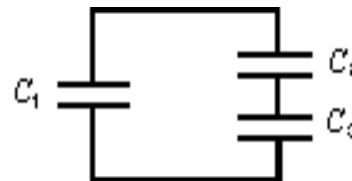

- a. $q_2 = 3.0 \times 10^{-8}$ and $q_3 = 1.0 \times 10^{-8} \text{ C}$
b. $q_2 = 1.0 \times 10^{-8}$ and $q_3 = 3.0 \times 10^{-8} \text{ C}$
c. $q_2 = 3.0 \times 10^{-8}$ and $q_3 = 3.0 \times 10^{-8} \text{ C}$
d. $q_2 = 2.0 \times 10^{-8}$ and $q_3 = 2.0 \times 10^{-8} \text{ C}$
e. $q_2 = 5.0 \times 10^{-8}$ and $q_3 = 1.0 \times 10^{-8} \text{ C}$

23. Each of the three $25 \mu\text{F}$ capacitors shown below is initially uncharged. How many coulombs of charge pass through the ammeter A after the switch S is closed?

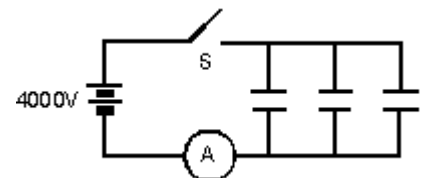

- a. 0.10 C b. 0.30 C c. 10 C
d. 0.05 C e. 0.5 C

24. A charged capacitor stores 10 C at 40 V. Its stored energy is:
 a. 400 J b. 4 J c. 0.2 J d. 2.5 J e. 200 J
25. An air-filled parallel plate capacitor has a capacitance of 1pF. The plate separation is then doubled and a wax dielectric is inserted, completely filling the space between the plates. As a result, the capacitance becomes 2 pF. The dielectric constant of the wax is:
 a. 0.25 b. 0.5 c. 2.0 d. 4.0 e. 8.0

Physics C Answer Key: **Orchid Test**
 March 13, 2014

1 –C	6 –D	11 –A	16 –A	21 –A
2 –C	7 –D	12 –B	17 –B	22 –C
3 –E	8 –D	13 –B	18 –B	23 –B
4 –A	9 –A	14 –C	19 –B	24 –E
5 –B	10 –D	15 –E	20 –C	25 –D

Physics C Science League Test
 April 10, 2014

DIRECTIONS: Please PRINT your name, school, area, and which test you are taking on the Scantron supplied. For each statement or question, completely fill in the appropriate space on the answer sheet. Use the letter preceding the word or phrase or sketch which best completes the statement or answers the question. Unless stated otherwise assume ideal conditions including no friction. Sketches are not to scale. Assume $g = -9.8\text{m/s}^2$

$$\mu_0 = 4\pi \times 10^{-7} \text{ N/A}^2 \quad k_m = \mu_0 / (4\pi) = 10^{-7} \text{ N/A}^2$$

1. Two long, parallel wires, separated by a distance r , carry currents I_1 and I_2 . The force of attraction has magnitude F . Which of the following combinations of current and distance will produce the same magnetic force F ?
 (A) $4I_1, 2I_2, 6r$ (B) $3I_1, 2I_2, 4r$ (C) $\frac{1}{2}I_1, 2I_2, 3r$ (D) $2I_1, 3I_2, 6r$ (E) $\frac{1}{3}I_1, 4I_2, 2r$
2. A square loop of wire of side 0.30 meters and resistance 0.60Ω is located in a uniform magnetic field of intensity $B = 1.80$ Tesla directed out of the page as shown. The magnitude of the magnetic field increases to 5.40 Tesla during a time period of 4.0 seconds. As the field increases, what are the magnitude and direction of the induced current in the loop?
- (A) 0.90 Amps, clockwise (B) 5.0 Amps, counterclockwise

(C) 12 Amps, counterclockwise (D) 0.135 Amps, clockwise

(E) 8.6 Amps, clockwise

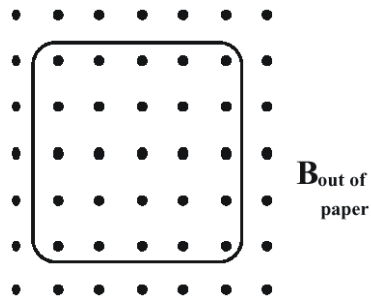

3. In which of the following cases does there exist a nonzero magnetic field that can be conveniently determined by using Ampere's law?
 (A) Outside a negative point charge that is stationary

- (B) Inside a stationary torus [donut shape] carrying a uniformly distributed charge
- (C) Inside a very long current-carrying solenoid
- (D) At the center of a current-carrying loop of wire
- (E) Outside a square current-carrying loop of wire

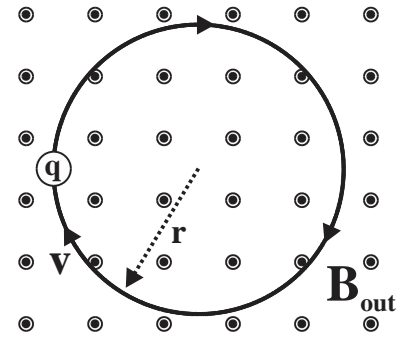
A charged particle, which has a mass m , follows a circular path which has a radius r with a velocity V within a uniform magnetic field B directed out of the page as shown to the right.

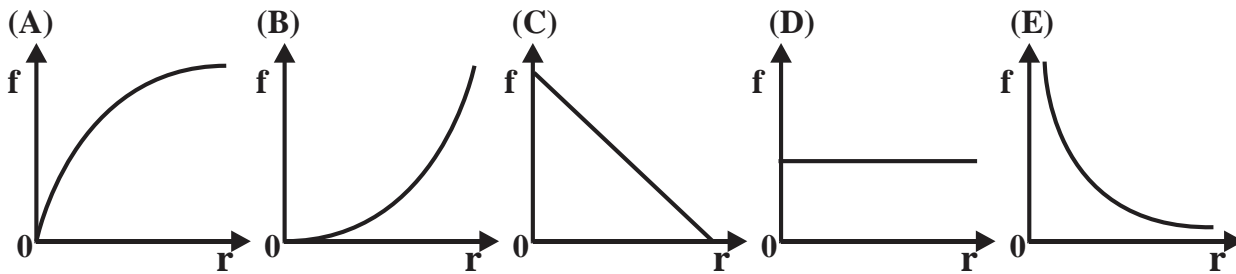

4. What is the charge of the particle?
- (A) $+m \cdot V/B$ (B) $-m \cdot V/(2 \cdot B)$ (C) $-m \cdot V/B^2$
 - (D) $+2 \cdot m \cdot V/B$ (E) $+m \cdot V/(r \cdot B)$
5. Which of the following graphs best depicts how the frequency of revolution f of the particle depends on the radius r ?



6. Which of the following statements about conductors under electrostatic conditions is true?
- (A) Positive work is required to move a positive charge over the surface of a conductor.
 - (B) The electric field at the surface of a conductor is always exactly perpendicular to the surface.
 - (C) The electric potential inside a conductor is always zero.
 - (D) The electric field at the surface of a conductor is tangent to the surface.
 - (E) Charge that is placed on the surface of a conductor always spreads evenly over the surface.

Questions 7-10 refer to the diagram at the right which shows a single rectangular loop of wire, which has a resistance R , located a distance a from a long straight conductor carrying a conventional current I_1 to the left.

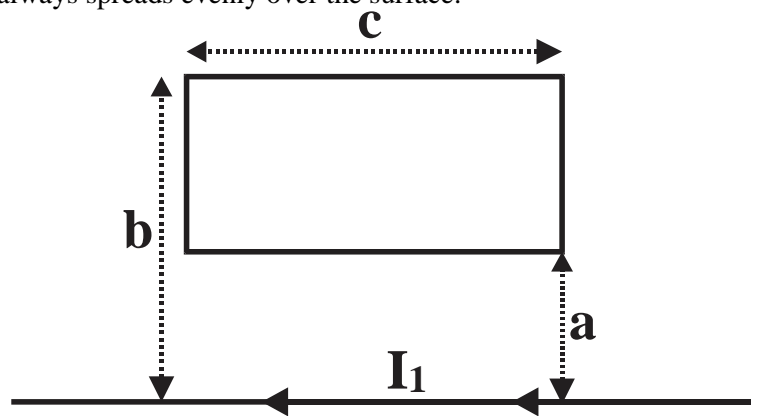

7. The magnetic field B within the loop of wire will be directed _____.
- (A) out of the page
 - (B) parallel to the long straight wire
 - (C) towards the top of the page
 - (D) towards the bottom of the page
 - (E) into the page
8. What will be the magnitude of the magnetic field B at the exact center of the rectangular loop?
- (A) $\mu_0 n I_1 / (a+b/2)$ (B) $\mu_0 N I_1 / c$ (C) $2 \mu_0 I_1$ (D) $4 \pi \mu_0 / (a+b/2)$ (E) $\mu_0 I_1 / [\pi(a+b)]$

9. What is the total magnetic flux through the rectangular loop of wire?

- (A) $\mu_0 I_1 \cdot (b-a)/4\pi c$ (B) $2\pi I_1 \cdot c[ab/(a-b)]$ (C) $4\pi I_1 \cdot c[ab/(a-b)]$
 (D) $\mu_0 I_1 \cdot c(b-a)/ab$ (E) $[\mu_0 I_1 c/2\pi] \cdot \ln(b/a)$

Suppose now that the current I_1 in the horizontal wire is varying according to the relationship $I_1 = I_0 \cdot (30 - 2 \cdot t)$.

10. What will be the resulting effect on the rectangular loop?

- (A) The rectangular loop will be repelled by the wire.
 (B) The rectangular loop will tend to be compressed.
 (C) A counterclockwise current will be induced in the rectangular loop.
 (D) The rectangular loop will be attracted by the wire.
 (E) Nothing will happen to the rectangular loop.

Questions #11, 12, and 13 refer to the circuit diagram to the right consisting of a source of EMF \mathcal{E} , two resistors R_1 and R_2 , two open switches S_1 and S_2 and an inductor L . At $t=0$ switch S_1 is suddenly closed while switch S_2 remains open.

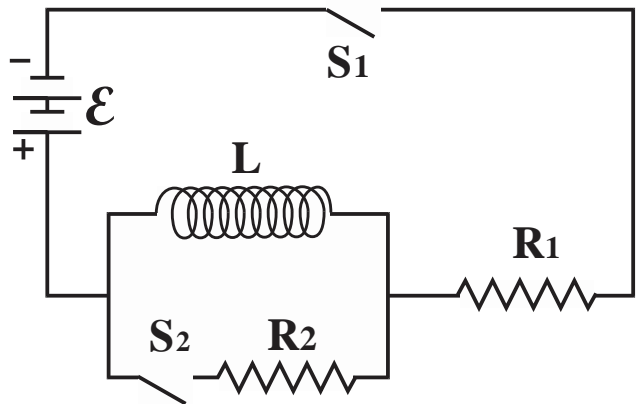

11. What will be the current flowing through resistor R_1 immediately after switch S_1 has been closed?

- (A) 0 (B) \mathcal{E}/R_1 (C) $\mathcal{E}/(R_1+R_2)$
 (D) $\mathcal{E}/(R_1-R_2)$ (E) $\mathcal{E}/R_1 + L/R_1$

12. What will be the potential difference across the inductor L a long time after the switch S_1 has been closed?

- (A) 0 (B) \mathcal{E} (C) $\mathcal{E} + I \cdot R_1$ (D) $\mathcal{E}/2$ (E) $\mathcal{E} \cdot R_1/(R_1+R_2)$

After switch S_1 has been closed for a long time switch S_2 is suddenly closed while simultaneously switch S_1 is opened.

13. What will be the potential difference across the inductor L immediately after switch S_2 has been closed?

- (A) 0 (B) \mathcal{E} (C) $\mathcal{E} \cdot R_2/(R_1+R_2)$ (D) $\mathcal{E} \cdot R_1/(R_1+R_2)$ (E) $\mathcal{E} \cdot R_2/R_1$

14. Which of the following elements is diamagnetic at room temperature? (atomic #)

- (A) iron(26) (B) manganese(25) (C) krypton(36) (D) cobalt(27) (E) nickel(28)

15. A bar magnet oriented as shown is moving toward the right at a constant velocity immediately over, but not touching a sheet of aluminum. Which of the following statements correctly describes what will happen?

- (A) The bar magnet will tend to rotate counterclockwise about a vertical axis through its geometric center.
 (B) Eddy currents in the surface of the aluminum sheet immediately below the magnet will exert a drag force to the left.
 (C) The magnet will be attracted towards the aluminum since aluminum is ferromagnetic.
 (D) There will be no effect since aluminum is not ferromagnetic.

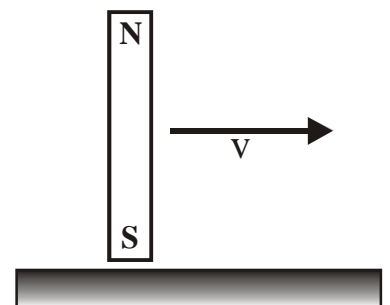

(E) The magnet will be repelled by the aluminum since aluminum is paramagnetic.

A current of I_{in} flows into the paper through a wire which has a radius of R . A point P is located a distance a from the center of the wire as shown to the right. The current density J within the wire varies according to $J=\alpha r$ where α is a positive constant and r is the distance from the center of the wire.

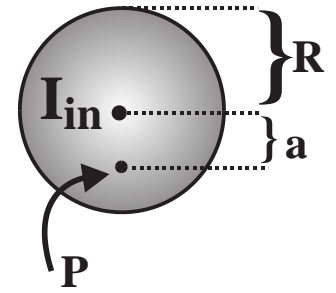

16. What will be the direction of the magnetic field at point P ?
- (A) towards the left side of the page (B) towards the top of the page
 (C) towards the right side of the page (D) into the page
 (E) towards the bottom of the page

17. What will be the magnitude of the magnetic field B at point P ?
- (A) $\mu_0\alpha a/4\pi$ (B) $\mu_0\alpha a^2/3$ (C) $\mu_0\alpha a^3/3$ (D) $\mu_0\alpha a/3\pi$ (E) $\mu_0\alpha a^3/4$

18. A circuit consists of a resistor R , an inductor L , and an open switch S connected in series with a battery \mathcal{E} . The switch is then closed at time $t = 0$. Which of the following quantities could be represented as a function of time by the graph shown?

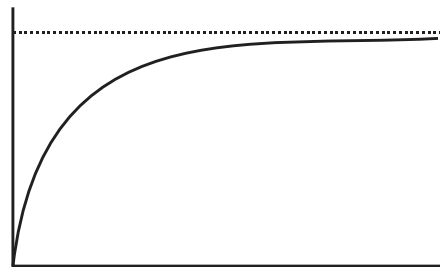
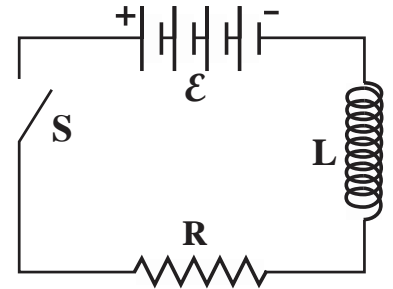

- I. The potential difference across the inductor L
 II. The current in the inductor L
 III. The current in the resistor R
 IV. The potential difference across the resistor R
- (A) I and IV only (B) III only
 (C) I and III only (D) II and III only
 (E) II, III, and IV only

In the diagram at the right a current of $I = 5.0$ Amperes is flowing through a loop of wire as shown. [Note that not all of each wire is shown in the diagram, each wire extends off to infinity!] Point P in the diagram is $R = 4.0$ cm from the loop of wire which consists of $3/4$ of a full circle.

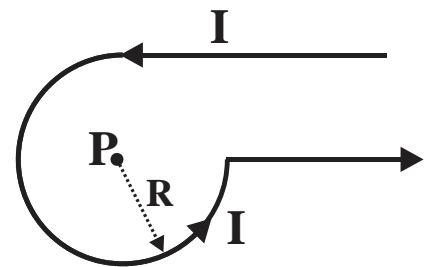

19. What will be the magnitude of the magnetic field at point P ?
- (A) 0.125 Gauss (B) 0.031 Gauss (C) 0.18 Gauss
 (D) 0.71 Gauss (E) 0.59 Gauss

A negatively charged particle $-q$, moving with a velocity \mathbf{V} , enters a uniform magnetic field \mathbf{B}_{out} directed out of the paper as shown to the right.

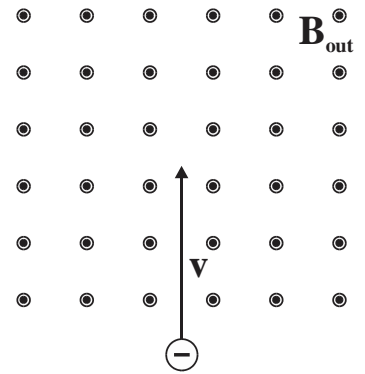

20. In what direction could an electric field \mathbf{E} be added so that the particle will pass through the magnetic field undeflected?

- (A) right (B) into the paper (C) out of the paper
(D) left (E) towards the bottom of the page

21. What is the velocity \mathbf{V} of this negatively charged particle if it is to pass through this area containing both an electric field \mathbf{E} and a magnetic field \mathbf{B} undeflected?

- (A) qB/E (B) qE/B (C) E/B (D) $-qE/B$ (E) $-qB/E$

22. A conducting loop is moving towards the right into a magnetic field directed into the paper as shown to the right. What will be the resulting effect on the loop of wire?

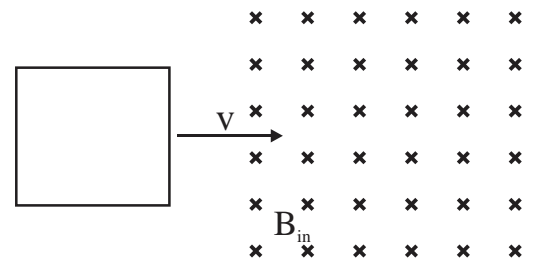

- (A) A clockwise current will flow in the loop after it has fully entered the field.
(B) A counter-clockwise current will flow in the loop after it has fully entered the field.
(C) There will be a constant counter-clockwise current while it enters the field dropping to zero after the loop has completely entered the field.
(D) A counterclockwise current will flow in the loop as it enters the field and the current will remain constant after the loop has completely entered the field.
(E) There will be no effect on the loop since there is no current flowing through it.

A coil of wire, which has a diameter of $d = 4.5$ centimeters, consists of 150 turns and has a resistance of 12.0Ω , is sitting in a uniform magnetic field, which has a field strength of $B = 1.15$ Tesla, directed into the paper as shown in the diagram to the right. This coil is then quickly rotated in a time period of 0.050 seconds until the normal to the plane of the coil has been rotated 180° . The figure to the right is for #23 only.

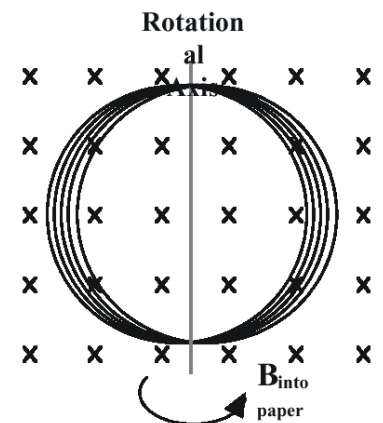

23. What will be the magnitude of the average EMF induced in this coil?

- (A) 2.20 Volts (B) 4.15 Volts (C) 5.5 Volts
(D) 1.25 Volts (E) 11.0 Volts

24. A positively charged particle in a uniform magnetic field is moving in a circular path of radius r perpendicular to the field. How much work does the magnetic force \mathbf{F}_m do on the charge for $\frac{3}{4}$ of a revolution?

- (A) $\pi \cdot r^2 F$ (B) $2\pi \cdot r F$ (C) $\pi \cdot r F$ (D) $2r F$ (E) Zero

25. A loop of wire is laying on a table in a vertically oriented magnetic field \mathbf{B} as shown to the right. All of the following changes will result in a current flow within the loop except:

- (A) rotating the loop clockwise on the table's surface
- (B) stretching the loop to make it larger
- (C) flipping the loop over
- (D) decreasing the magnitude of the external magnetic field \mathbf{B}
- (E) changing the angle between the magnetic field and the normal to the surface of the table

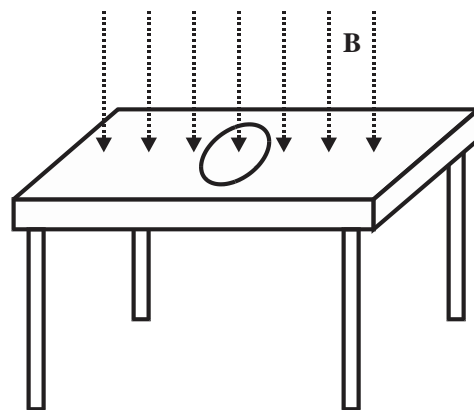

Physics C Answer Key: Orchid Test

April 13, 2014

Record onto the area record the % correct

1.	D	6.	B	11.	A	16.	A	21.	C
2.	D	7.	E	12.	A	17.	B	22.	C
3.	C	8	E	13.	E	18	E	23.	E
4.	E	9.	E	14.	C	19.	D	24	E
5.	D	10.	D	15.	B	20.	D	25.	A

