

## NJSL Environmental Science January 2014 Exam

Choose the answer that best completes the statements or questions below and fill in the appropriate response on the form. If you change an answer be sure to completely erase your first choice. Please PRINT your name, school, area, and which test you are taking onto the scan-tron.

1. What term describes a social movement dedicated to protecting the natural world from undesirable changes brought about by human actions?
  - a. the environment
  - b. environmental science
  - c. environmentalism
  - d. ecological footprint
2. A human-centered view of our relationship with the environment is known as
  - a. Biocentrism.
  - b. Ecocentrism.
  - c. Anthropocentrism.
  - d. Environmentalism.
3. Which of the following is an example of a nonrenewable natural resource?
  - a. wind energy
  - b. sunlight
  - c. natural gas
  - d. geothermal energy
4. Which of the following is an example of quantitative data?
  - a. There are 13 dorsal spines on the lionfish.
  - b. The lionfish are brown and striped.
  - c. Lionfish have attractive fleshy tentacles.
  - d. b and c are correct.
5. Results published in \_\_\_\_\_ are the most respected in science because they have passed through a rigorous evaluation process involving feedback from multiple sources.
  - a. news magazines
  - b. peer-reviewed journals
  - c. web journals
  - d. weekly newspapers
6. Which statement below aligns most with the graph between 1965 to 1968?
  - a. The wolf population experienced a steady decline, while the moose population increased.
  - b. The moose population experienced a steady decline, while the wolf population increased.
  - c. Both the moose and the wolf populations sharply decreased.
  - d. Both the moose and the wolf populations sharply increased.
7. What has happened to resource consumption in the last several hundred years?
  - a. It has remained at the same level.
  - b. It has decreased only slightly.
  - c. It has increased dramatically.
  - d. It has decreased dramatically.

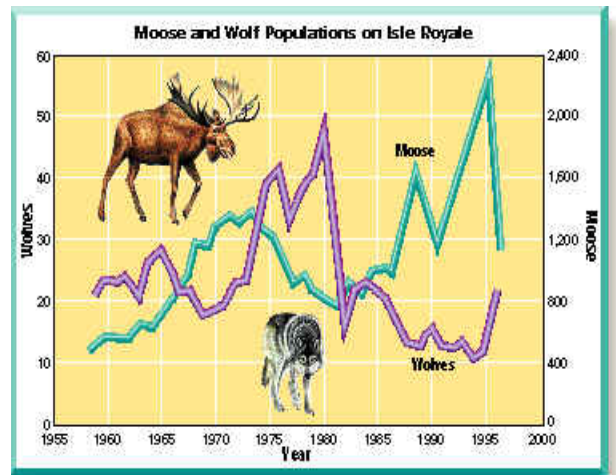

8. Natural resources that are naturally replenished over months, years, or decades are called

- a. nonrenewable resources.
- b. fossil fuels.
- c. footprints.
- d. renewable resources.

9. This is what scientists use to test a prediction when they cannot use an experiment.

- a. hypothesis
- b. probability
- c. correlation
- d. statistics

10. Which water quality test would indicate a high number of suspended solids in a sample?

- a. Nitrates
- b. Phosphates
- c. Dissolved Oxygen
- d. Turbidity

11. The graph to the right shows the growth of a bacterial population. Which of the following correctly describes the growth curve?

- a. logistic
- b. limiting
- c. exponential
- d. demographic

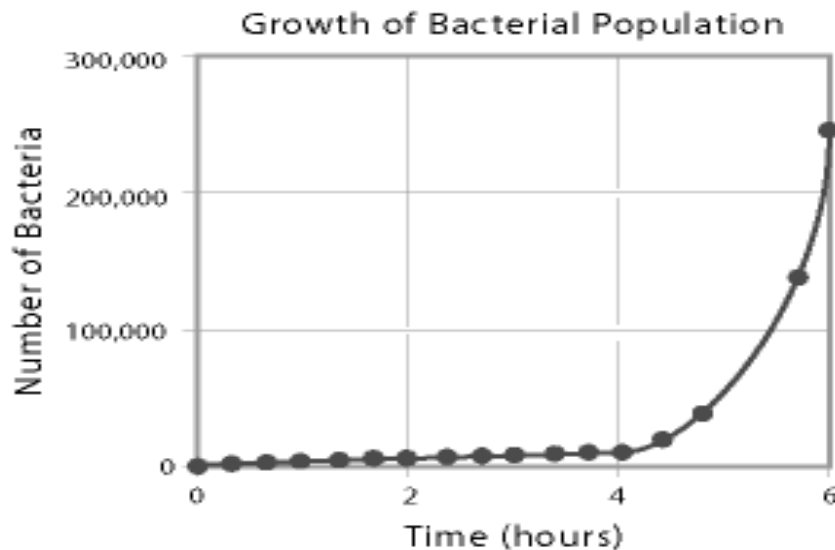

12. What tool would be very useful to geologists because they cannot easily perform experiments to test the effects of tectonic plate motion?

- a. predictions
- b. controlled studies
- c. modeling
- d. independent variables

13. In an experiment, a scientist adds fertilizer to one pond in order to compare the algae growth to a pond that does not receive fertilizer. The amount of algae that grows would represent a(n)

- a. model.
- b. dependent variable.
- c. prediction.
- d. independent variable.

14. What happens after a scientist submits results for publication in a scientific journal?

- a. The scientist will then present the results at a conference.
- b. Several other scientists specializing in the subject will examine the manuscript.
- c. The scientist then begins a new area of research.
- d. The results will be printed immediately.

15. What is one of the key differences between scientific theories and hypotheses?
- Theories are tested by experiments and observations, but hypotheses are not.
  - Hypotheses are subject to peer review, but theories are not.
  - Theories are broader explanations, whereas hypotheses deal with a narrower subject.
  - Hypotheses can be proven wrong, but theories cannot.
16. An idea must effectively explain a phenomenon, make accurate predictions in a wide range of situations, and have undergone extensive, rigorous testing, to be accepted as a scientific
- prediction.
  - theory.
  - ethic.
  - hypothesis.
17. A set of moral principles or values held by a person or a society is called
- ethics.
  - justice.
  - culture.
  - biocentrism.
18. Which of the following would exhibit primary succession?
- rock exposed by a retreating glacier
  - an abandoned farm
  - a forest that had been clear-cut
  - newly flooded land to create a reservoir
19. Tigers living in warm climates have thinner coats of fur than tigers living in cool climates. This is a result of
- genetic diversity.
  - species diversity.
  - ecosystem diversity.
  - general diversity.
20. In immature ecosystems
- the species diversity is high.
  - the decomposers are numerous.
  - there are many specialized niches.
  - the food webs are simple.
21. The easiest component of biodiversity to measure is
- ecosystem diversity.
  - species diversity.
  - genetic diversity.
  - ecosystem health.
22. Which is the most direct way in which biodiversity can provide a source of income?
- medicines
  - ecotourism
  - research
  - agriculture
23. If current trends continue, the modern geologic era, known as the Quaternary period, may see the extinction of
- almost 20 percent of all species.
  - more than half of all species.
  - all species on Earth.
  - one or two species per century..
24. The Convention on International Trade in Endangered Species of Wild Fauna and Flora (CITES) and the Convention on Biological Diversity are examples of
- organizations that promote ending poaching.
  - polls measuring American opinion about biodiversity.
  - treaties to protect biodiversity.
  - laws to increase the number of species.

25. To manage, protect, and reintroduce threatened and endangered species are the goals of
- wildlife corridors.
  - conservation concessions.
  - Species Survival Plans.
  - biodiversity hotspots.
26. Which of the following is an example of a method for managing whole ecosystems and habitats?
- captive breeding
  - cloning
  - Species Survival Plans (SSPs)
  - mapping biodiversity hotspots
27. Relieving a nation from repaying some of the money it owes other nations in exchange for protecting its biodiversity is called a
- debt-for-nature swap.
  - conservation concession.
  - Species Survival Plan.
  - wildlife corridor.
28. The latitudinal gradient is a natural pattern in which species diversity generally
- increases toward the equator.
  - decreases toward the prime meridian.
  - decreases in warmer climates.
  - increases toward the poles.
29. Which type of organism has the greatest species diversity?
- plants
  - mammals
  - insects
  - protists
30. High levels of biodiversity tend to
- have little or no effect on ecosystems.
  - decrease an ecosystem's resistance.
  - make an ecosystem less resilient.
  - increase the stability of an ecosystem.
31. In which way are plants in a sunny mountain meadow and sulfur bacteria in a deep-sea volcanic vent alike?
- They both use photosynthesis to make their own food.
  - They both produce carbohydrates and oxygen.
  - They both use chemosynthesis to produce their own food.
  - They both produce carbon and hydrogen.
32. A species that is at serious risk of extinction is called a(n)
- threatened species.
  - invasive species.
  - endangered species.
  - extirpated species.
33. By far, the biggest cause of biodiversity loss today is
- climate change.
  - over harvesting.
  - habitat change and fragmentation.
  - pollution.
34. What global phenomenon has caused some organisms to move toward the poles or to higher altitudes?
- habitat fragmentation
  - pollution
  - invasive species
  - warming temperatures
35. In the United States, what is the major law that protects biodiversity?
- Convention on Biological Diversity
  - Endangered Species Act
  - U.S. Fish and Wildlife Service
  - Species Survival Plan

36. A treaty is a(n)
- a. state law to protect wildlife.
  - b. agreement under international law.
  - c. trade-off with landowners.
  - d. biodiversity program run by zoos.
37. The group of organisms that convert light into food are called:
- a. omnivores
  - b. decomposers
  - c. heterotrophs
  - d. autotrophs
38. Which of the following represents single-species approaches to protecting biodiversity?
- a. building wildlife corridors
  - b. selling conservation concessions
  - c. captive breeding and cloning
  - d. mapping biodiversity hotspots
39. Day-to-day conditions in Earth's atmosphere, such as "sunny and humid," describe
- a. climate.
  - b. climatograph.
  - c. weather.
  - d. biome.
40. Arrange the following biomes in terms of **increasing** net primary production.
- |            |                   |                 |            |
|------------|-------------------|-----------------|------------|
| I. Savanna | II. Boreal Forest | III. Coral Reef | IV. Desert |
|------------|-------------------|-----------------|------------|
- a. I < II < III < IV
  - b. II < III < I < IV
  - c. IV < I < II < III
  - d. IV < II < I < III
41. In aquatic ecosystems, net primary productivity is related to
- a. whether the water is fresh water or saltwater.
  - b. the speed at which the water moves.
  - c. available sunlight and nutrients.
  - d. waves and tides.
42. What percentage of Earth's surface is covered in water?
- a. 75 percent
  - b. 90 percent
  - c. 25 percent
  - d. 50 percent
43. Which of the following describes the aphotic zone in an aquatic ecosystem?
- a. the very bottom of a body of water
  - b. the zone where no sunlight penetrates and photosynthesis cannot occur
  - c. the shallow, near-shore zone
  - d. the uppermost layer where there is enough sunlight for photosynthesis
44. Which zone of an aquatic ecosystem tends to have more life—both producers and consumers?
- a. aphotic zone
  - b. photic zone
  - c. benthic zone
  - d. All have roughly the same amounts of life.

45. What type of biome is most likely represented by this graph?

- a. Tundra      c. chaparral
- b. coral reef    d. deciduous forest

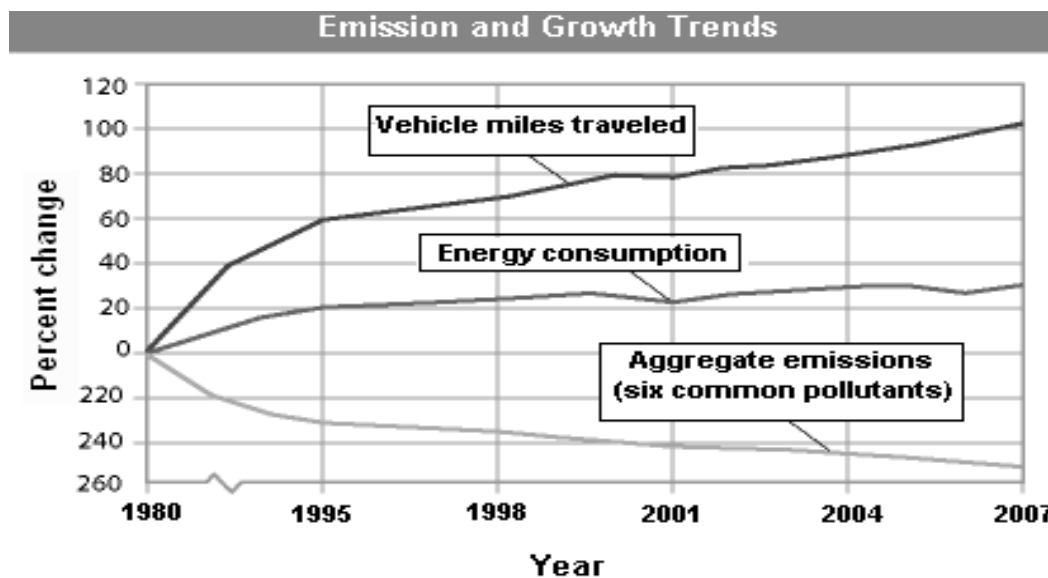
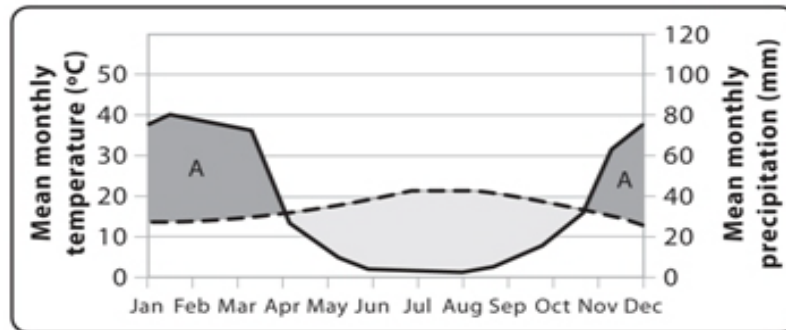

46. The graph above shows the relationship between miles a vehicle is driven to the energy consumed and the emissions produced. Which statement below is supported by the graph?

- a. Less energy is used when people travel farther by car.
- b. Although people are traveling more by car, pollution has decreased.
- c. Pollution increases as energy consumption increases.
- d. Energy consumption has changed more than total emissions.

47. A bog is a wetland that

- a. is entirely covered with thick, floating mats of vegetation.
- b. has shallow water and tall, grass like plants.
- c. has shallow water and woody shrubs and trees.
- d. has mostly salt water.

48. Compared to forests, grasslands have
- a. more diversity, more inertia.
  - b. more diversity, more resilience.
  - c. less diversity, more inertia.
  - d. less diversity, more resilience.
49. In 2007, the annual growth rate for a country is 1.5%. Approximately how many years would it take for the population to double?
- a. 105
  - b. 466
  - c. 47
  - d. 54
50. Ecologists use similarities between ecosystems to classify them into broad categories called
- a. biomes.
  - b. littoral zones.
  - c. estuaries.
  - d. benthic zones.
51. Which biome would have the lowest net primary production?
- a. tropical rain forest
  - b. temperate grassland
  - c. coral reef
  - d. desert
52. Over a given unit of time, the rate at which plants and algae convert solar or chemical energy into energy stored in the bonds of organic sugars is called
- a. natural selection.
  - b. gross primary production.
  - c. salinity.
  - d. estivation.
53. Why do shorter trees and plants that make up the understory in tropical rain forests have large, flat leaves?
- a. to shade themselves from excessive sunlight
  - b. to create habitat for forest insects
  - c. to offer protection from rain
  - d. to allow maximum surface for light absorption
54. In temperate rain forests, trees such as cedars and spruces, which do not lose their leaves at any time of year, are called
- a. coniferous.
  - b. succulent.
  - c. chaparral.
  - d. deciduous.
55. To help them survive in the tundra, caribou have various adaptations, such as
- a. thin coats of fur to prevent overheating.
  - b. wide hooves for travel on mud and snow.
  - c. a diet that consists mostly of deciduous tree leaves.
  - d. the ability to hibernate.
56. What biome is the most prevalent along the equator?
- a. Tropical rain forest
  - b. Deciduous forest
  - c. Tundra
  - d. Tiaga

57. Criteria such as salinity, depth, and whether the water is flowing or standing are used by scientists to
- classify aquatic ecosystems.
  - measure net primary productivity in lakes.
  - distinguish aquatic ecosystems from terrestrial ecosystems.
  - determine the number of species in a body of water.
58. Water with a salinity that is greater than fresh water but less than saltwater is classified as
- photic.
  - aphotic.
  - brackish.
  - littoral.
59. Which zone of an aquatic ecosystem tends to have the highest temperatures?
- photic zone
  - aphotic zone
  - benthic zone
  - All have roughly the same temperatures.
60. Which statement about the littoral zone in a lake or pond is true?
- There are no rooted aquatic plants.
  - It has deep water.
  - It is far from the shore.
  - It is rich in invertebrates.
61. Marshes, swamps, and bogs are examples of
- terrestrial biomes.
  - freshwater wetlands.
  - estuaries.
  - ocean zones.
62. What is the difference between swamps and freshwater marshes?
- Swamps have deep water, but marshes have shallow water.
  - Swamps have mostly woody shrubs and trees, but marshes have mostly grasses.
  - Swamps usually have saltwater, but marshes have fresh water.
  - Swamps have lots of wildlife, but marshes do not.
63. Where rivers flow into the ocean, mixing fresh water with saltwater, brackish ecosystems occur which are called
- bogs.
  - flood plains
  - estuaries
  - limnetic zones

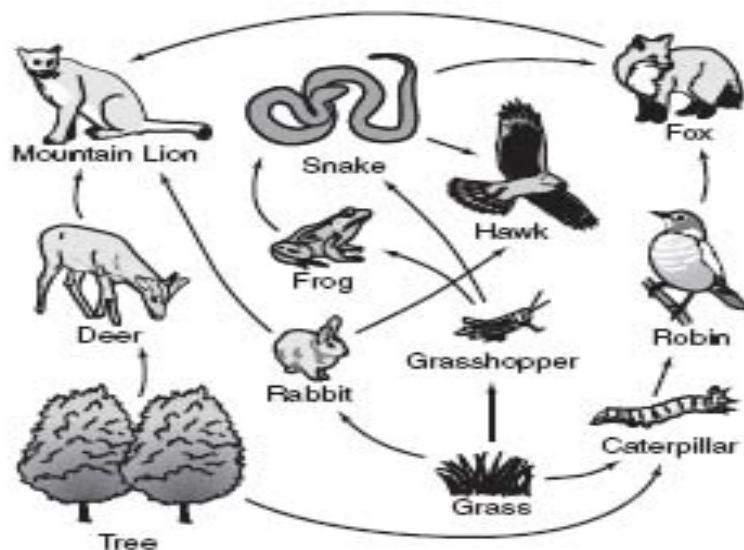



64. Which of the following is a food chain in the food web shown above?
- a. tree, rabbit, hawk, snake
  - b. grass, grasshopper, snake, hawk
  - c. grass, caterpillar, robin, hawk
  - d. tree, deer, mountain lion, fox

65. Success at solving an environmental problem is more likely when researchers follow the basic principles of ecology because

- a. ecological solutions to problems are usually very easy to implement and can be done quickly.
- b. most people in the world are more interested in saving the environment than in their own comfort and convenience.
- c. ecology uses scientific research to identify the cause of the problem and the best practices to solve the problem.
- d. ecologists are very good at influencing government officials into changing laws to improve the environment.

66. Natural capital consists of \_\_\_\_\_ and ecological services.

- a. resources
- b. economic services
- c. climate change
- d. gross national product

67. Use the graph below to answer the question # 67.

Which point most closely aligns with the Agricultural Revolution?

- a. Point A
- b. Point B
- c. Point C

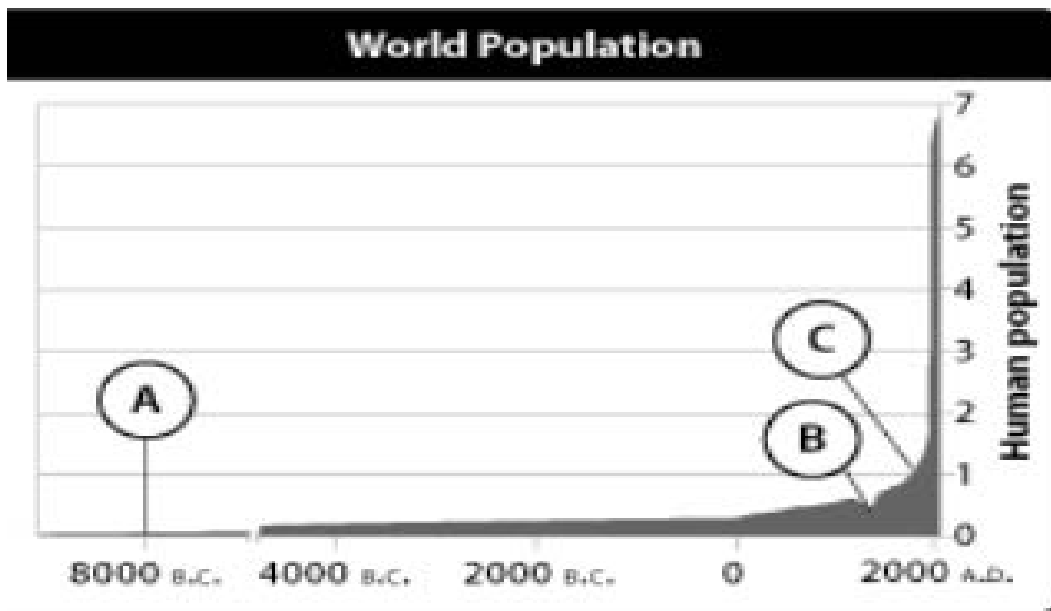

68. Examples of a situation where a long time delay results in environmental degradation include
- a. clear-cutting a forest.
  - b. building new four-lane highways.
  - c. depletion of the ozone layer.
  - d. fish kills from oil spills.

69. In the "Tragedy of the Commons" the commons is
- a. Disputed border territory
  - b. Stolen goods or winnings
  - c. Any shared and limited resource
  - d. Any individual's private property.

70. In the field, you observe a lion chase, kill, and eat a gazelle. A vulture pecks away at the leftover meat scraps. Beetles attack the remaining fragments. Finally, bacteria complete the breakdown and recycling of organic material. If you were to apply a general classification to the feeders, what would be the correct sequence?

- a. decomposer → scavenger → detritus feeder → carnivore
- b. carnivore → detritus feeder → scavenger → decomposer
- c. carnivore → scavenger → detritus feeder → decomposer
- d. carnivore → scavenger → decomposer → detritus feeder

**NEW JERSEY SCIENCE LEAGUE**

**Environmental Science Answer Key: Green test.**

**Fill in Date: January 2014 Exam correct ans ( )**

1	C	15	C	29	C	43	B	57	A
2	C	16	B	30	D	44	B	58	C
3	C	17	A	31	C(all full)	45	C(all full)	59	A
4	A	18	A	32	C	46	B(all full)	60	D
5	B	19	A	33	C	47	A	61	B
6	A	20	D	34	D	48	C	62	B
7	C	21	B	35	B	49	C	63	C
8	D	22	B	36	B	50	A	64	B
9	C	23	B	37	D	51	D	65	C
10	D	24	C	38	C	52	B	66	A
11	C	25	C	39	C	53	D	67	A
12	C	26	D	40	C(D)	54	A	68	C
13	B	27	A	41	C	55	B	69	C
14	B	28	A	42	A	56	A	70	C

**NJSL Environmental Science February 2014 Exam**

Choose the answer that best completes the statements or questions below and fill in the appropriate response on the form. If you change an answer be sure to completely erase your first choice. Please PRINT your name, school, area, and which test you are taking onto the scan-tron.

1. The easiest component of biodiversity to measure is
  - a. ecosystem diversity.
  - b. species diversity.
  - c. genetic diversity.
  - d. ecosystem health.
  
2. Fire as a tool of forest management
  - a. has been banned because the resulting destruction is greater than the benefits.
  - b. is very controversial among forest scientists since there is no agreement that fires are beneficial.
  - c. is important in removing organic debris so that larger forest fires may be prevented.
  - d. has been banned because of the danger of uncontrolled wildfires.

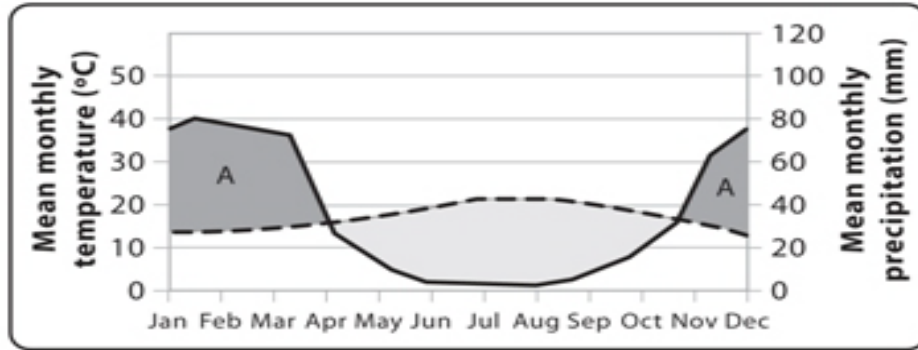

3. In the graph above, the solid line represents precipitation and the dashed line represents temperature. What type of conditions are indicated by the areas of the graph labeled A?
  - a. hot
  - b. humid
  - c. dry
  - d. freezing
  
4. Which combination of factors will produce the highest rate of population growth?
  - a. high life expectancy and high infant mortality
  - b. low life expectancy and low infant mortality
  - c. low life expectancy and high infant mortality
  - d. high life expectancy and low infant mortality

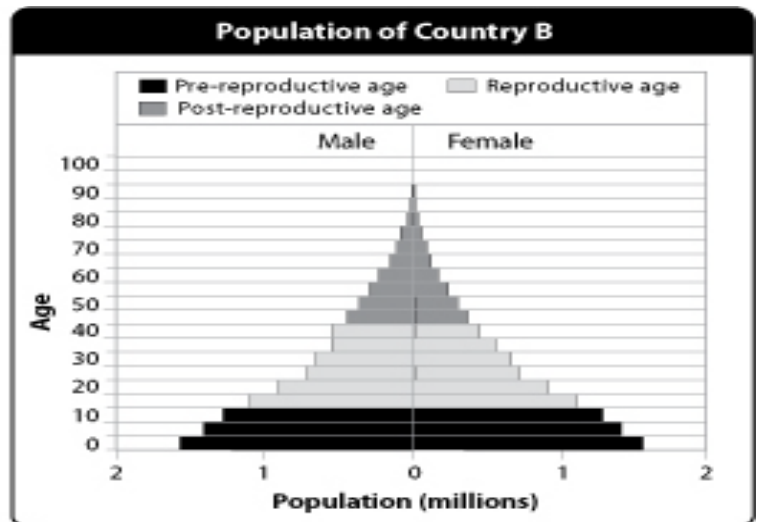
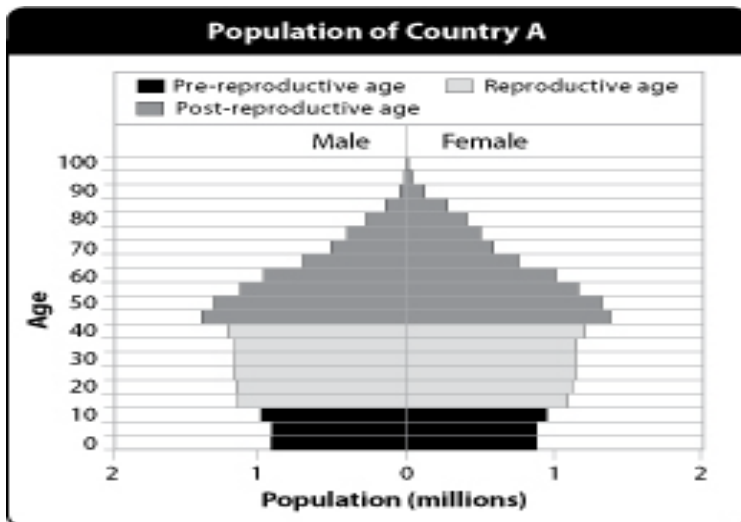

5. Consider the two population pyramids above from the year 2005. Which statement about the graphs is true?
  - a. Country A will have a rapid growth of population
  - b. Country B will have a rapid growth of population
  - c. Both countries have about the same growth rate
  - d. Both countries have about the same population in the age group from 0 to 15.

6. From greatest to least, rank the primary uses of fresh water around the world.
  - a. personal, industry, agriculture
  - b. industry, agriculture, personal
  - c. agriculture, industry, personal
  - d. industry, personal, agriculture
  
7. What is the correct hierarchy of taxonomic groups, from largest to smallest?
  - a. order, family, genus, species
  - b. genus, family, order, species
  - c. family, genus, order, species
  - d. genus, family, species, order
  
8. If the world's population grew by 2% in 1998 and continued at that rate, how many years would it take for the Earth's population to double?
  - a. 20
  - b. 25
  - c. 30
  - d. 35
  
9. CFCs break down in the stratosphere under the influence of
  - a. UV radiation.
  - b. Infrared radiation
  - c. low air pressure
  - d. ozone
  
10. If the thermohaline circulation constantly moving through the oceans as a result of temperature differences were to slow or stop, what would likely happen?
  - a. Europe would become much hotter.
  - b. Europe would become much colder.
  - c. Northeastern North America would become much hotter.
  - d. North America would suffer floods and severe storms.

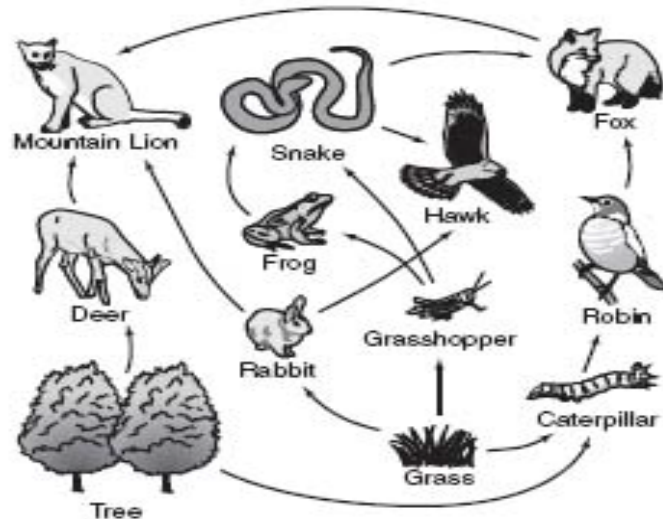

11. If a persistent organic pollutant were to enter the above food web, where would the greatest levels of the pollutant bioaccumulate?
  - a. Snakes, caterpillars, rabbits
  - b. Grasses, deer, robins
  - c. Grasses, trees, grasshoppers
  - d. Hawks, mountain lions, foxes
  
12. Which biome would have the lowest net primary production?
  - a. tropical rain forest
  - b. temperate grassland
  - c. coral reef
  - d. desert

13. Over a given unit of time, the rate at which plants and algae convert solar or chemical energy into energy stored in the bonds of organic sugars is called
- a. natural selection.
  - b. gross primary production.
  - c. salinity.
  - d. estivation.
14. In nature, it is difficult to observe the effects density-independent limiting factors have on real populations because density-independent limiting factors
- a. strike only dense populations.
  - b. often have a greater effect on denser populations.
  - c. usually do not have any effect on populations.
  - d. usually affect only a small part of a habitat.
15. Which of the following descriptions about the organization of an ecosystem is correct?
- a. Communities make up species, which make up populations.
  - b. Populations make up species, which make up communities.
  - c. Species make up communities, which make up populations.
  - d. Species make up populations, which make up communities.
16. Total impact on the environment is increased by all of the following EXCEPT,
- a. Technology.
  - b. Affluence.
  - c. Green spaces.
  - d. Population.
17. The human population in Canada contains almost equal numbers of people in each age group. This means that the population in Canada will
- a. double in 30 years.
  - b. grow slowly but steadily.
  - c. decrease exponentially.
  - d. decrease to its carrying capacity.
18. How does an area's weather differ from the area's climate?
- a. Weather involves temperature and precipitation and climate involves only temperature.
  - b. An area's weather depends on where it is located on Earth and the area's climate does not.
  - c. An area's weather does not change very much and an area's climate changes many times.
  - d. Weather is the area's day-to-day conditions and climate is the area's average conditions.
19. The greenhouse effect is
- a. something that has only occurred for the last 50 years.
  - b. a natural phenomenon that maintains Earth's temperature range.
  - c. the result of the differences in the angle of the sun's rays.
  - d. an unnatural phenomenon that causes heat energy to be radiated back into the atmosphere.
20. Earth has three main climate zones because of the differences in latitude and, thus,
- a. amount of precipitation received.
  - b. distribution of sunlight.
  - c. ocean currents.
  - d. prevailing winds.
21. Which of the following is a biological aspect of an organism's niche?
- a. the water in the area
  - b. the way it gets food
  - c. amount of sunlight
  - d. composition of soil



22. What would happen if the population of the bird species shown in the ecosystem in the figure above were to suddenly decrease?
- The grass population would increase.
  - The fish population would increase.
  - The fish would occupy the birds' niche.
  - The grass and fish would compete for resources.
23. How is parasitism different from commensalism?
- Both organisms benefit in parasitism and only one organism benefits in commensalism.
  - One organism benefits in parasitism and no organisms benefit in commensalism.
  - One organism is harmed in parasitism and both organisms are harmed in commensalism.
  - One organism is harmed in parasitism and no organisms are harmed in commensalism.
24. What is one difference between primary and secondary succession?
- Primary succession is rapid and secondary succession is slow.
  - Secondary succession begins on soil and primary succession begins on newly exposed surfaces.
  - Primary succession modifies the environment and secondary succession does not.
  - Secondary succession begins with lichens and primary succession begins with trees.
25. Which is a factor that could interrupt the progress of succession?
- colonization of surfaces by lichens
  - different animals appearing at each stage
  - natural disturbances
  - long-term fluctuations in climate
26. Consider succession in an ecosystem. What would be found in a climax community?
- lichens and moss
  - trees and shrubs
  - weeds and grasses
  - volcanoes and soil
27. Arctic ecosystems are considered marine ecosystems because
- arctic ecosystems contain an enormous amount of frozen sea water.
  - arctic ecosystems are inhabited by few organisms and sunlight is limited
  - phytoplankton form the basis of arctic food webs
  - arctic ecosystems are cold

28. The nutrient availability of aquatic ecosystems is the
- amount of nitrogen, oxygen, and other elements dissolved in the water.
  - number of other organisms present in the water.
  - amount of rainfall the water receives.
  - number of different animal species living in the water.
29. Freshwater ecosystems that originate from underground sources in mountains or hills often result in
- estuaries.
  - rivers and streams.
  - lakes and ponds.
  - wetlands.
30. Estuaries are commercially important because
- fish species that people buy and sell live in estuaries.
  - tall buildings can be built in estuaries.
  - lumber trees grow in estuaries.
  - fossil fuels are found in estuaries.
31. Which of the following statements is NOT true about the open ocean?
- The open ocean has low levels of nutrients.
  - Organisms in the deep ocean are exposed to frigid temperatures and total darkness.
  - The open ocean begins at the low-tide mark and extends to the end of the continental shelf.
  - Most of the photosynthetic activity on Earth occurs in the open ocean within the photic zone.
32. What is a population's total fertility rate?
- the number of births needed to keep a nation's population stable
  - the average number of children a male member of a population has each year
  - the average number of children a female member of the population has during her lifetime
  - the total number of babies born in a population each generation
33. Which is the proper sequence of steps in the demographic transition model?
- pre-industrial, industrial, post-industrial, transitional
  - pre-industrial, transitional, industrial, post-industrial
  - transitional, pre-industrial, industrial, post-industrial
  - post-industrial, transitional, industrial, pre-industrial
34. What happens during the transitional stage of the demographic transition?
- Birthrates begin to fall.
  - Death rates begin to fall.
  - Birth rates increase.
  - Death rates increase.
35. Which of the following countries has yet to go through the demographic transition?
- Japan
  - United States
  - India
  - Germany
36. In which of the following countries would individuals have the largest ecological footprints?
- India
  - China
  - Canada
  - Thailand
37. The richest one fifth of the world's people uses what percent of the world's resources?
- 5
  - 20
  - 43
  - 86
38. The average number of years an individual is predicted to live is called
- carrying capacity.
  - life expectancy.
  - growth rate.
  - demography.



39. Which area would have the lowest population density?  
 a. seacoast in Europe    b. river in China    c. tundra in Russia    d. suburb in the U.S.A.
40. Which factor(s) help increase total fertility rates?  
 a. needing extra help on farms  
 b. government programs supporting older adults  
 c. more children surviving childhood  
 d. one-child policies
41. What does the replacement fertility rate depend on the most?  
 a. population growth    b. demography    c. total fertility rate    d. death rate
42. What can be inferred about an area that has an age structure diagram with a pyramid shape?  
 a. The population is likely to decrease in the future.  
 b. There is a high proportion of older people to younger people.  
 c. There is a high population growth rate.  
 d. There is a low population growth rate.
43. What could be inferred about an area that has an age structure diagram with a “barrel” shape (thicker in the middle, narrower on the top and bottom)?  
 a. There is low population growth.  
 b. The population is likely to increase in the future.  
 c. There is a high proportion of young people to older people.  
 d. There is high population growth.
44. The number of males compared to females in a population is the  
 a. age structure.    b. sex ratio.    c. total fertility rate.    d. demography.
45. Which stage of the demographic transition is characterized by conditions that have defined most of human history?  
 a. industrial    b. pre-industrial    c. post-industrial    d. transitional
46. Which of the following countries is considered developed?  
 a. China    b. Mexico    c. Australia    d. Croatia

**Energy flow for a region known as Green Springs (kcal/m<sup>2</sup>/yr).**

Tropic Level	Energy Available (kcal/m <sup>2</sup> /yr)
Producers	9000
Primary Consumers (herbivores)	1500
Secondary Consumers (carnivores)	120
Tertiary Consumers (top carnivores)	12

**Use the energy flow chart above for questions 47 and 48.**

47. The calculated efficiency of energy transfer (in percent) from producers to primary consumers is  
 a. 10%    b. 16.7%    c. 8%    d. 80%



Figure: Age structure comparison. Use the graphic above for questions 56-59.

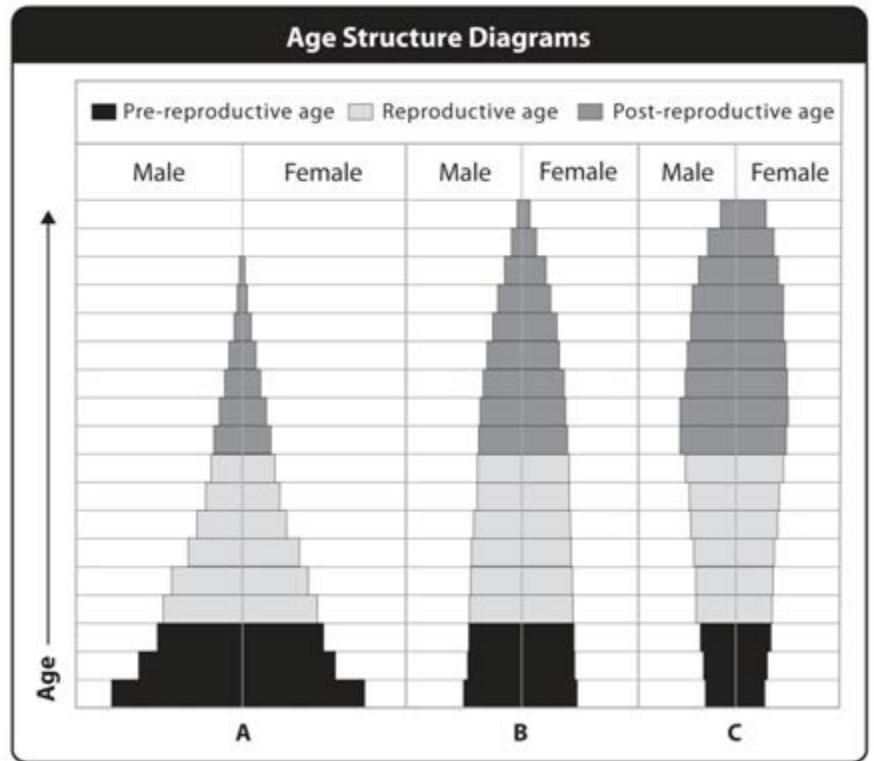

56. In which of the populations above would you expect to see a rapid increase within the next few generations?  
 a. A    b. B    c. C  
 d. None of the above

57. Imagine that the graphs above show populations of three different species that people want to protect. Which species is likely to need the most protection and management in the near future?  
 a. A    b. B    c. C  
 d. None of the above

58. One of these populations has a long generation time and it has been at carrying capacity for several generations, but habitat and resources are abundant and the population isn't likely to change soon. Which population is it?  
 a. A    b. B    c. C    d. None of the above

59. Which population has the highest proportion of reproductive individuals?  
 a. A    b. B    c. C    d. None of the above

60. The dangers of disposing of toxic chemicals underground came to public attention in which of the following locations?  
 a. Bhopal, India    b. Chernobyl, Ukraine    c. Love Canal, New York    d. Minamata, Japan

**Question 61 refers to the table below, which shows population, area, and energy use of several countries.**

61. The country with the highest population density is  
 a. Australia  
 b. Bangladesh  
 c. China  
 d. Ethiopia

Country	Population (millions)	Approximate Total Land Area (million km <sup>2</sup> )
Australia	19.7	8.2
Bangladesh	144	0.14
China	1,295	9.6
Ethiopia	70	1.12
India	1,000	3.29
United States	300	9.63

62. Which of the following practices would have the biggest impact on achieving global sustainability?
- Recycling aluminum cans
  - Using fuel-efficient vehicles
  - Replanting deforested areas
  - Reducing human population size
63. The current global human population is about 7.1 billion (7,100,000,000) and is growing at an approximate annual rate of 1.1%. At this rate approximately how many people would be added to the world in one year?
- 780,000
  - 7,800,000
  - 78,000,000
  - 780,000,000
64. Slowing population growth occurs due to all of the following reasons, EXCEPT:
- Reducing poverty
  - Elevating the status of women
  - Encouraging family planning
  - Focusing global education on young boys
65. A population with a crude birth rate of 46 and a crude death rate of 12 is growing at what annual percentage rate? [rate = (birth rate – death rate)x 10]
- 5.8
  - 3.4
  - 58
  - 34
66. A city with a population 10,000 experiences 100 births, 40 deaths, 10 immigrants, and 30 emigrants in the course of a year. What is the population of the city at the end of the year?
- 10,040
  - 10,100
  - 10,060
  - 10,030
67. Which of the following organisms would be an example of an *r-strategist*?
- whale
  - dog
  - alligator
  - cockroach
68. Which factor helps increase total fertility rates?
- needing extra help on farms
  - government programs supporting older adults
  - more children surviving childhood
  - one-child policies
69. According to the \_\_\_\_\_, there is a range for physical conditions and concentrations of substances beyond which no members of a particular species can survive.
- limiting factor principle
  - law of tolerance
  - law of conservation of mass
  - first law of thermodynamics

70. The graph below shows the changes in the world population over time. The trend shown in the graph would most likely result in:

- A decreased demand for deforestation
- An increase in air pollution
- An increase in available fresh water
- An increased demand for land.

- I and II only
- III only
- II and IV only
- II, III, and IV

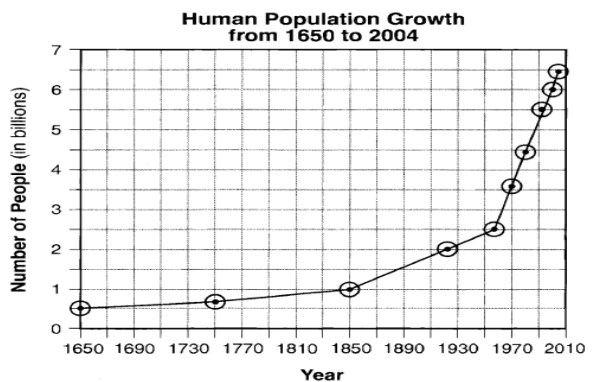

NEW JERSEY SCIENCE LEAGUE

Environmental Science Answer Key: **Green test.**

February 13, 2014 (Correct ans)

1	B	15	D	29	B	43	A	57	C
2	C	16	C	30	A	44	B	58	B
3	B	17	B	31	C	45	B	59	A
4	D	18	D	32	C	46	C	60	C
5	B	19	B	33	B	47	B	61	B
6	C	20	B	34	B	48	C	62	D(all full credit)
7	A	21	B	35	C	49	A	63	C
8	D	22	B	36	C	50	B	64	D
9	A	23	D	37	D	51	D	65	B
10	B	24	B	38	B	52	A	66	A
11	D	25	C	39	C	53	B	67	D
12	D	26	B	40	A	54	D	68	A
13	B	27	C	41	D	55	D(all full credit)	69	A
14	B(D)	28	A	42	C	56	A	70	C

**NJSL Environmental Science Exam**  
**March 2014 Yellow problem questions.**

Choose the answer that best completes the statements or questions below and fill in the appropriate response on the form. If you change an answer, be sure to completely erase your first choice. Please PRINT your name, school, area, and which test you are taking onto the scan-tron.

**AIR POLLUTION & CLIMATE CHANGE:**

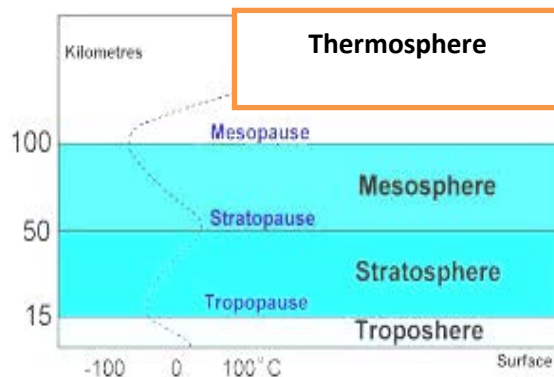

Source: <http://app2.nea.gov.sg/training-knowledge-hub/weather-climate>

Diagram of layers of atmosphere and location:

- |                                      |                      |
|--------------------------------------|----------------------|
| A. All of the atmospheric layers     | D. Troposphere       |
| B. Thermosphere and upper mesosphere | E. None of the above |
| C. Stratosphere                      |                      |

Using the letters (A-E) corresponding to the answers above, identify where each of the following would be found or found in greatest amounts:

1. Aurora borealis
2. Most of our weather patterns occur in this layer
3. Ozone layer blocking UV light
4. Particulate matter
5. The collection of all gases held to Earth by gravity
6. Ground level ozone
7. Nitrifying bacteria that convert N<sub>2</sub> Gas to nitrate
8. Volcanic dust from huge volcanoes like Mt. Pinatubo

For questions # 9-13 select from the following list of pollutants found in air we breathe.

- A. Particulate matter
  - B. NO<sub>x</sub> (nitrogen oxides)
  - C. CO (carbon monoxide)
  - D. O<sub>3</sub> (ozone)
  - E. SO<sub>x</sub> (sulfur oxides)
9. Volcanoes & power generation - electricity from coal power plants are major sources of this
  10. Transportation and industrial combustion are two major sources of this pollutant.
  11. Construction and farming are some typical sources
  12. The source is vehicle exhaust in sunlight
  13. Vehicle exhaust and power generation are major sources of this pollutant

**Ozone Air Quality, 1980 - 2012**  
 (Annual 4th Maximum of Daily Max 8-Hour Average)  
 National Trend based on 230 Sites

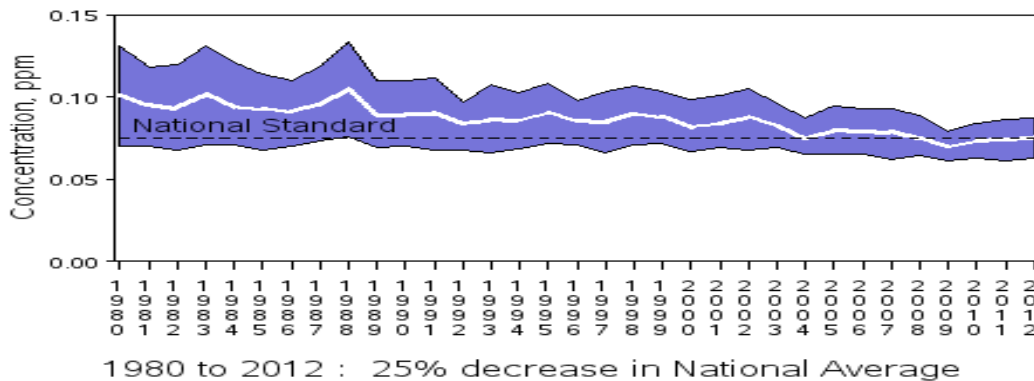

Source: <http://www.epa.gov/airtrends/ozone.html#oznat> Ozone concentration (ppm) as measured by the National Standard of Ozone Air Quality from 1980- 2012 has changed significantly. The national average is the white line in the graph above.

14. Refer to the graph above. The national average of ozone air quality in 1980 was:
- A. 0.12 ppm
  - B. 0.68 ppm
  - C. 0.10 ppm
  - D. 10 ppm
  - E. 1.2 ppm
15. The ground level ozone presents a danger to human health. It can result in the following:
- A. Reduce lung function, inflames tissue, worsens asthma, bronchitis & chronic conditions
  - B. Cause chest pain, coughing, throat irritation
  - C. Permanently scar lung tissue with long term exposure
  - D. All of the above
16. The major factors involved in thinning the ozone layer over Antarctica in the Antarctic Spring include all of the following **except**:
- A. the vortex formed in the fall
  - B. photochemical smog
  - C. chlorine containing compounds
  - D. sunlight and polar stratospheric clouds
17. Ozone depletion results in:
- A. Cooling of lower stratosphere since 1980 (-0.6°C/decade from 1979 – 1994)
  - B. Changes in surface UV radiation; O<sub>3</sub> is responsible for absorbing 99% of UV < less than 320 nm , ( UV-A (320-400 nm), UV-B (280-320 nm)
  - C. UV-B exposure may cause sunburn, skin cancer , cataracts
  - D. UV-B exposure may cause decreased crop yields
  - E. All of the above.

18. In 1883, the volcano Krakatoa exploded, sending ash and sulfurous gas into the atmosphere, where they persisted for at least 3 years. Which of the following phenomena would have resulted from the greatest amount of dust in the atmosphere?

- A. A decrease in global temperature
- B. An increase in global temperature because of the greenhouse effect
- C. An increase in sea level
- D. Deposition of microspherules

**AIR POLLUTION LAB:** To investigate some of the effects of common industrial pollution (ozone, acid rain, and other forms of air pollution) on plants, researchers can measure several factors. Among those factors are growth patterns (height increase & total weight gain of roots) & physiological functions (rate of photosynthesis and activity of key enzymes, such as ATPase).

**Study 1** - Over a 6-month period, 4 groups (I, II, III, and IV) of 50 young pine trees of the same species were grown in a greenhouse under identical soil, light, temperature, and water conditions.

- Group I was grown in an unpolluted greenhouse.
- Group II was saturated with simulated acid rain at pH 3.5 (about 100 times more acidic than normal rain) for 20 hours per week.
- Group III was grown in an ozone-rich atmosphere.
- Group IV was grown under combined acid rain and ozone conditions.

At the end of the 6-month period, the increase in height and total root weights were measured for each of the trees. The data, averaged by group, appear in Table 1.

TABLE 1		
Group	Group height (cm)	Increase in total root weight (g)
I	5	30
II	4	25
III	3	12
IV	3.5	14

19. The conditions experienced by which of the following groups in Study 1 most closely resemble those which would be found in a heavily industrialized area?

- A. Group I only
- B. Group IV only
- C. Groups I and II only
- D. Groups I and IV only

20. What group's total root weight was most negatively impacted ?

- A. Group I
- B. Group II
- C. Group III
- D. Group IV

21. Which group's height in cm was most negatively impacted?

- A. Group I
- B. Group II
- C. Group III
- D. Group IV



**Study 2** - During the same 6-month period, 4 other groups (V, VI, VII, and VIII) of 50 young pines of the same species were grown under the same conditions as those described in Study 1. Researchers measured photosynthetic rates and ATPase activities of the trees in each group. These results, averaged for each group, appear in Table 2 below.

Group V was grown in an unpolluted greenhouse,  
 Group VI received acid rain at pH 3.5 for 20 hours per week.  
 Group VII was grown in an ozone-rich atmosphere, and  
 Group VIII was grown under combined acid rain and ozone conditions.

TABLE 2		
Group	Photosynthetic rate (mg CO <sub>2</sub> used/min))	ATPase activity (% of normal)
V	100	100
Vi	95	60
VII	50	48
VIII	55	47

22. Which of the following groups served as the experimental control in Study 2 ?

- A. Group V                      B. Group VI                      C. Group VII                      D. Group VIII  
 E. No control was needed since plants are exposed to pollutants all the time.

23. According to the results of Study 2, compared with pines exposed to only acid rain, pines exposed to both acid rain and an ozone-rich atmosphere had:

- A. higher photosynthetic rates and higher ATPase activity.  
 B. higher photosynthetic rates and lower ATPase activity.  
 C. lower photosynthetic rates and higher ATPase activity.  
 D. lower photosynthetic rates and lower ATPase activity

24. On the basis of these studies alone, are the researchers correct in generalizing that ozone is the most harmful pollutant in the atmosphere?

- A. Yes, because the ozone affected the pines more than other pollutants would.  
 B. Yes, because if pines are harmed by ozone, then all other plants will be as well.  
 C. No, because the researchers tested only 400 plants.  
 D. No, because the researchers tested only 2 pollutants

The Diagram below represents two **insulated cups**, each filled with equal masses of water. One insulated cup contains cold water, the other warm water. A metal bar is inserted in the water of each.



25. Assume that each cup is insulated and filled with water: one has hot water, the other cool. Heat energy will be transferred through the bar from one cup to the other primarily by

- A. electromagnetic rays flowing currents
- B. molecular collisions
- C. density differences
- D. flowing currents

26. In this diagram, if all the energy lost by the warm water is gained by the cold water, what will be the temperature of the water in both insulated cups following the energy transfer? Warm water starts at 40 degrees C , cool starts at 10 degrees C.

- A. 50 degrees C
- B. 25 degrees C
- C. 10 degrees C
- D. 20 degrees
- E. not enough info

Use the same diagram but remove the thermometer and metal bar.

27. Let's assume we place a light source **equal distance** from both cups. Also assume that the cups are not insulated and both start out at the **same initial temperature**. One cup is black, the other is white. After the light source is on, the amount of radiant energy striking the black container, as compared to the amount striking the white container, is

- A. less
- B. more
- C. the same
- D. not enough info to determine

28. Let's assume we place a light source **equal distance** from both cups. Also assume that the cups start out at the **same initial temperature**. After the light source is on, the amount of radiant energy being absorbed by the surface of the black container, as compared to the amount of energy absorbed by the surface of the white container, is

- A. less
- B. more
- C. the same
- D. not enough info to determine

Base your answer to questions 29 and 30 on the information about a laboratory procedure, diagram, and data table below. Hot water at 90°C is poured into cup A. Cool water at 20°C is poured into cup B. Styrofoam covers are placed on the cups. An aluminum bar & a thermometer are placed through holes in each cover. Points X & Y are locations on the aluminum bar. The data table shows temperature readings taken every minute for 20 minutes.

29. The rate of temperature change in cup A for the first 10 minutes was approximately:

- A. 0.77 C°/min
- B. 1.3 C°/min
- C. 7.7 C°/min
- D. 13.0 C°/min

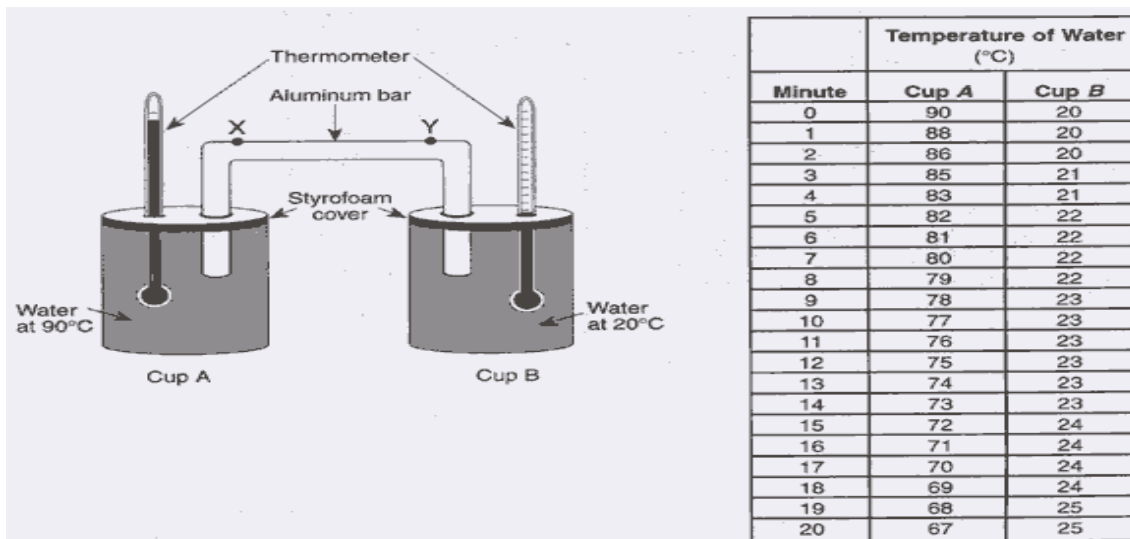

30. Which change in the experiment would increase the heating rate of the water in cup B?
- making the aluminum bar shorter between points X and Y
  - making the aluminum bar longer between points X and Y
  - keeping cup A covered, but uncovering cup B
  - keeping cup B covered, but uncovering cup A
31. Lead has been an environmental issue. Exposure sources include all of the following except :
- transformers on utility poles
  - solder in copper pipes
  - crystal and make-up
  - air near lead smelters plants
  - pencils, gas and paint before the 1980's
32. The EPA has set national ambient air quality standards (NAAQS) for:
- carbon dioxide
  - radon
  - water vapor
  - lead
33. The table below is a chart of the children with elevated blood lead levels which are  $\geq 20 \mu\text{g/dL}$ . If you were asked to interpret the graph, all of the following would be accurate **except**:
- There was ~ a 50% decline in numbers between 1994 and 1997
  - The greatest annual percentage of change took place between 1994 and 1995
  - During the 7 year period levels dropped to approximately 20% of the 1994 numbers
  - The greatest annual decrease in numbers occurred between 1994 and 1995

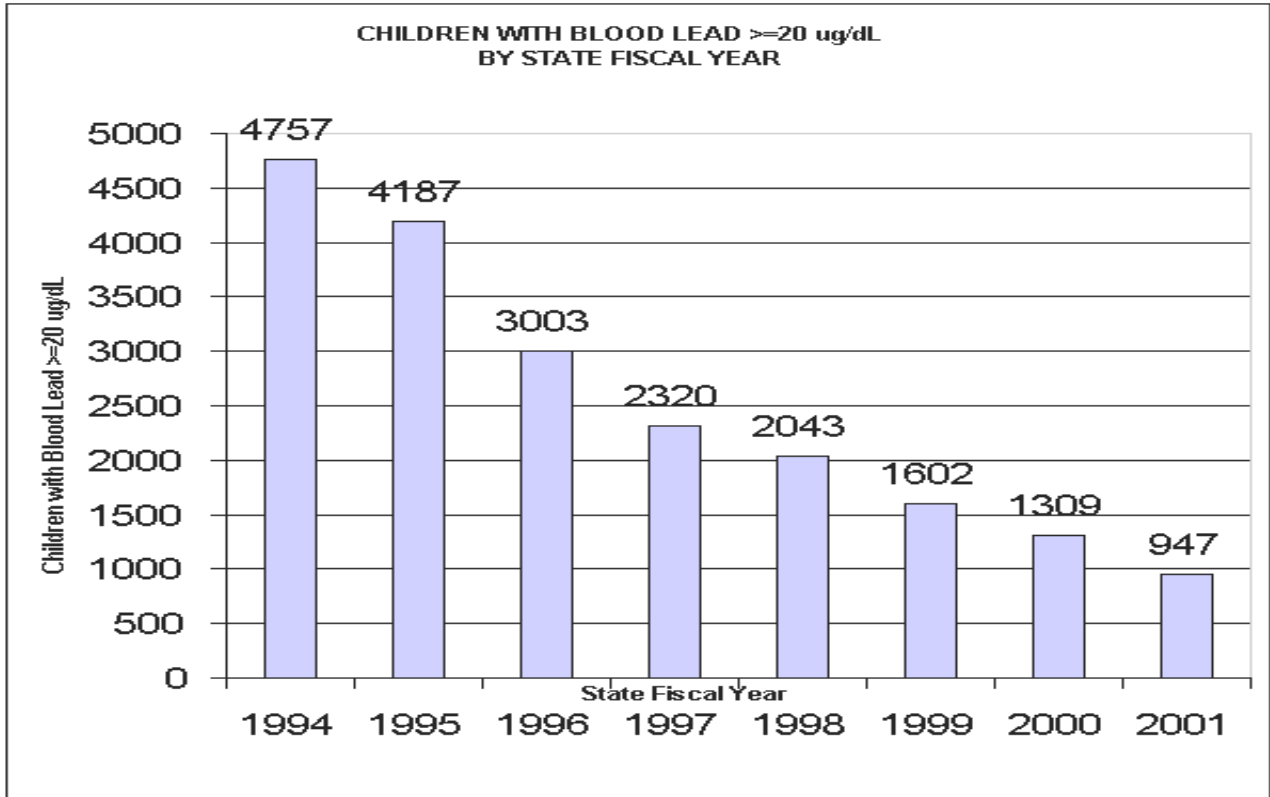

Source: <http://www.clper.org/putativedeclines.html>

It has been researched and hypothesized that there is a relationship between declining violent crimes rates approximately 21 years after lead was removed from paint and gasoline. Lead in house paint was banned in 1978. In gasoline lead began being phased out in 1973 with lead being completely banned in gasoline in 1996. Below is one graph from the study done by Rick Nevins

REMOVAL OF LEAD FROM GASOLINE AND PAINT LINKED TO DROP IN VIOLENT CRIME.

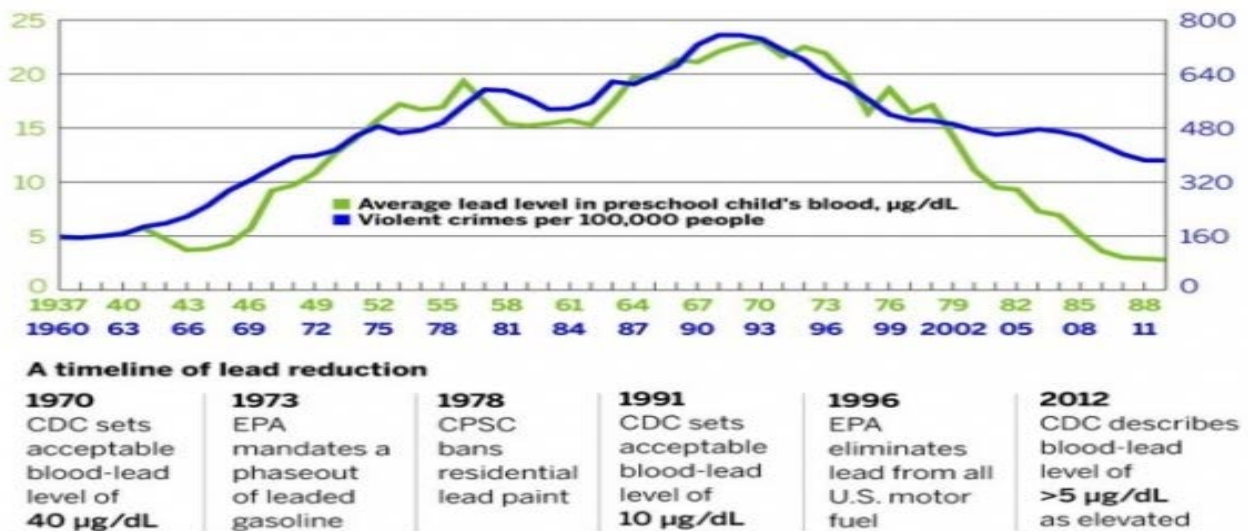

34. What does the graph above indicate about the relationship between lead in preschool children and violent crimes?

- A. proves there is a connection there is a relationship between the two.
- B. shows there is an inverse relationship
- C. suggests a positive correlation between the two
- D. suggests a negative correlation between the two

Use the graph below to answer questions 35 and 36.

35. When studying the drop in lead levels between 1988 through 2002 depicted in the graph, the largest decrease in children ages 1-5 with blood lead levels > 10 µg/dL occurs in what population?

- A. Black, non-Hispanic children
- B. Mexican American children
- C. White, non-Hispanic children
- D. cannot determine, need more information

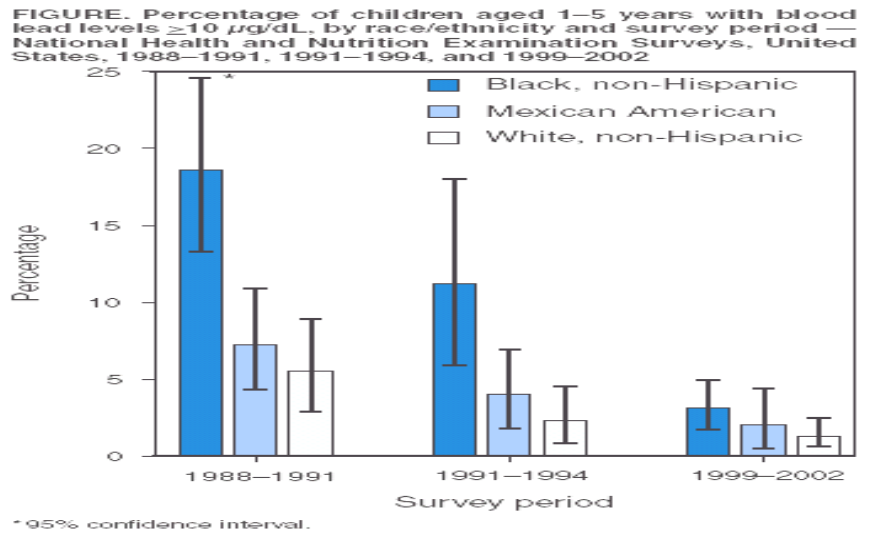

36. The symbol which sits on the top of each bar in the graph above represents:

- A. the mean
- B. the median
- C. the confidence interval
- D. the % decrease

Source <http://www.cdc.gov/mmwr/preview/mmwrhtml/mm5420a5.htm#fig>

Radon is a radioactive gas formed from the decay of radioactive materials (such as uranium or radium) in soil, bedrock, underground water, and air. Radon’s radioactivity can be harmful to humans if radon is breathed at high levels over long periods of time. Radon is the leading cause of lung cancer in non-smokers. In recent years, it has been recognized as a problem in homes throughout the world and in our state NJ. Anyone buying a new home is required to have the radon tested prior to purchasing in NJ. Radon concentrations are measured in picocuries per liter (pCi/L). The picocurie is a measure of radioactivity. Outdoor air is very low in radon, usually less than 1 pCi/L. Levels in a home that are greater than 4 pCi/L are considered potentially harmful. Homeowners with levels above 4 picocuries/Liter are advised to fix or remediate the levels to avoid risk of lung cancer. Below is a map of NJ counties.

37. After Hurricane Sandy, houses in some of the NJ coastal areas were required to be built above grade (on stilts) to keep the houses above water should future storms incur similar flooding damage. Which would one most likely predict about the radon gas hazard from soil in those houses?

- A. Radon would accumulate to high levels in the lowest floor of those houses.
- B. Radon would accumulate to high levels in the highest floor of those houses.
- C. Radon would not be a hazard because the drinking water is aerated inside the houses.

D. Radon would not be a hazard because the lowest floor is not in contact with soil or bedrock

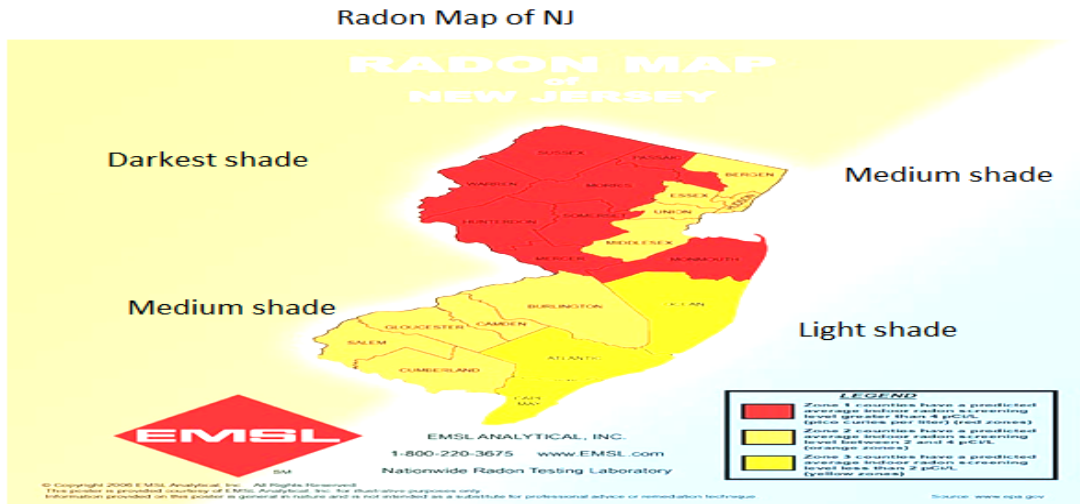

**KEY: PREDICTED AVERAGE INDOOR RADON SCREENING LEVELS:** Darkest shaded areas = greater than 4pCu/L, Medium shaded areas = between 2-4pCu/L. Lightest shaded areas = less than 2pCu/L.

38. If you live in Bergen, Essex, Hudson, Union, or Middlesex counties of NJ, your predicted indoor radon screening levels are:

- A. > 4pCu/L
- B. between 2-4pCu/L.
- C. less than 2pCu/L.
- D. safe, no need to test
- E. might be safe but testing is advised

39. What general area is the most at risk from radon related lung cancer in non-smokers?

- A. northwest
- B. southeast counties
- C. southwest counties
- D. northeast counties

Climate change factors – Radiative forcing is the influence any particular factor has on the energy balance of the atmosphere-land-ocean system. *Positive forcing* leads to atmospheric warming; negative to atmospheric cooling. Identify each of the following as positive or negative forcing effects

40. The following lead to positive forcing with the exception of :

- A. volcanic activity
- B. high wispy clouds in planetary albedo
- C. industrial aerosols
- D. sooty aerosols
- E. all of the above

41. Which map (A, B, C or D) best represents the global prevailing surface wind patterns responsible for generating Atlantic Ocean currents?

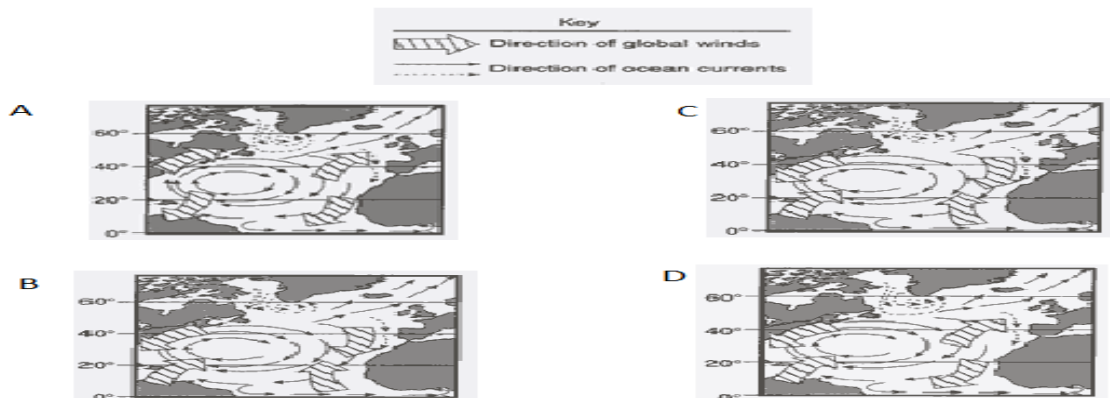

42. Biological magnification can occur with many substances. When we eat fish such as tuna or other high order consumers the most likely substance found in it is:

- A. Radon      B. Lead   C. Mercury      D. Organophosphates      E. Cadmium

Use the map of the USA below to answer the following question.

43. Springfield, Missouri, and San Francisco, California, are at similar latitudes, but they have very different climates. Springfield has very hot summers and cold winters, while San Francisco has about the same temperatures all year. What is the most likely reason the two cities have such different climates?



- A. the amount of sunlight on each city  
 B. the distance of each city from an ocean  
 C. the elevation above sea level of each city  
 D. the distance of each city from the equator

**SOIL TEXTURE & POROSITY LAB** Source: <https://www.okhighered.org/epas/content-guides/science.pdf>

A soil's texture is the proportion of its particles that fall within 3 size categories: sand (the largest), silt, and clay (the smallest). Texture affects the rate at which water can drain through a soil. Soils high in sand commonly drain quickly, since there is a relatively large amount of interconnected space between sand grains. Soils containing large proportions of silt or clay particles drain more slowly, since the spaces between their particles are relatively small and not well connected. The following experiments were conducted to investigate the effect of texture on the drainage of water through different soils.

Table 1 Soil Type	Percentage sand	Percentage silt	Percentage clay
Sandy loam	65	20	15
Loam	40	42	18
Clay loam	34	31	35
Silty loam	17	70	13
Silty clay	10	45	45

**Study 1** - Samples of 5 soils were collected. All particles larger than sand were removed from each sample by passing the sample through a screen. Next, each sample was passed through 2 screens: The first trapped the sand-size particles; the second caught the silt particles, but allowed the clay to pass through it. The percentage (by weight) of the different particle sizes is shown in the table.

**Study 2** Three funnels were lined with filter paper, and into each one was placed an equal-size sample of a different soil: sandy loam, clay loam, and silty clay. A volume of 250 mL of water was poured into each funnel. The amount of water that passed through each sample, and the time it took for the water to stop draining through each sample, are as follows:

Type	Water drain in ml	Time
sandy loam	150 mL	75 sec.
clay loam	125 mL	90 sec.
silty clay	63 mL	150 sec.

44. Which of the following statements best describes the purpose of the filter paper in Study 2?
- To absorb all the water poured onto the samples
  - To add weight to the sample
  - To provide a porous container for the soil
  - To prevent the passage of water through the soil
45. What was the purpose of measuring the amount of water drained through the soils in Study 2?
- To determine how much water is transmitted by various soil textures
  - To help determine the weight percent of sand in the three soils
  - To test the rate at which water evaporated in the laboratory
  - To help compare the weight percent of clay in the loam soil with that in the silty clay soil
46. Soil conservation techniques that help prevent erosion include all of these except:
- intercropping and crop rotation
  - contour and terrace farming
  - tilling and shelterbelts
  - biological pest control and integrated pest management IPM

**HERBICIDE INVESTIGATION** Herbicides are chemicals that kill plants. A study was conducted to examine the effects of 2 herbicides (Herbicides A and B) on both crop and weed plant species. Ten identical 10 m × 10 m plots were established in a field. One row of seeds of each of 5 crop species and 5 weed species was planted in each plot. One herbicide at 1 of 2 concentrations was then added to each plot (see Table 1). Plants were observed 2 weeks after application of the herbicides. Plots 1–5 were used in Experiment 1 and Plots 6–10 were used in Experiment 2

Plot	Herbicide	Concentration
1 and 6	A	Low
2 and 7	A	High
3 and 8	B	Low
4 and 9	B	High
5 and 10	None	-

**Experiment 1** -Herbicides were applied to the plots immediately after the seeds were planted (**pre-emergence**)

	PLOT				
	1	2	3	4	5
<b>CROPS</b>					
CORN	-	X	-	-	-
CUCUMBER	-	X	X	X	-
OATS	X	X	-	-	-
TOMATO	-	-	X	X	-
WHEAT	X	X	-	-	-
<b>WEEDS</b>					
CRABGRASS	X	X	-	-	-
QUACK GRASS	X	X	-	-	-
FOXTAIL	-	-	-	-	-
RAGWEED	X	X	X	X	-
VELVETLEAF	-	-	-	X	-

	Plot				
	6	7	8	9	10
<b>CROPS</b>					
CORN	-	X	-	-	-
CUCUMBER	I	X	-	I	-
OATS	X	X	-	-	-
TOMATO	I	X	-	I	-
WHEAT	X	X	-	-	-
<b>WEEDS</b>					
CRABGRASS	X	X	-	-	-
QUACK GRASS	X	X	-	-	-
FOXTAIL	-	-	X	X	-
RAGWEED	I	X	I	X	-
VELVETLEAF	I	X	-	-	-



application). Results - Table 2. (Key [X] = plants died and [-] = plants were not affected.)

**Experiment 2** - The herbicides were applied to the plots only after the plants had emerged from the soil and were 6–12 cm tall (**post-emergence** application). Table 3 presents the results. (Note: [ I ] indicates that the plants were injured by the herbicide.)

At the end of the experiments, all plots were seeded with bluegrass in order to prevent soil erosion.

47. Which of the plots served as the control in Experiment 2 ?

- A. Plot 6    B Plot 7            C Plot 8 D Plot 9            E Plot 10

48. In which of the following ways were the procedures of Experiments 1 and 2 different?

- A. Herbicide concentrations    B. Size of the plots    C. Plant species tested    D. Timing of herbicide application

49. Based on the results of Experiment 1, one can conclude that Herbicide A has no effect on which of the following crop species after pre-emergence application?

- A. cucumber            B oats            C tomato            D wheat

50. The study plots used in the experiments were as identical as possible in order to ensure:

- A. environmental conditions in each of the plots were about the same.  
B. herbicides could be applied at the appropriate time during the growing season.  
C. crop and weed species would respond to the herbicides.  
D. number of plants which emerged could be counted.

51. What herbicide & application technique would be used to prevent foxtail based upon the results?

- A. Herbicide A – pre-emergence application  
B. Herbicide A – post-emergence application  
C. Herbicide B – pre-emergence application  
D. Herbicide B – post-emergence application

Source: <https://www.okhighered.org/epas/content-guides/science>

52. Which zones below are most likely to have a temperate climate ?

- A. 1 and 6  
B. 2 and 5  
C. 3 and 4  
D. 1, 2, and 3

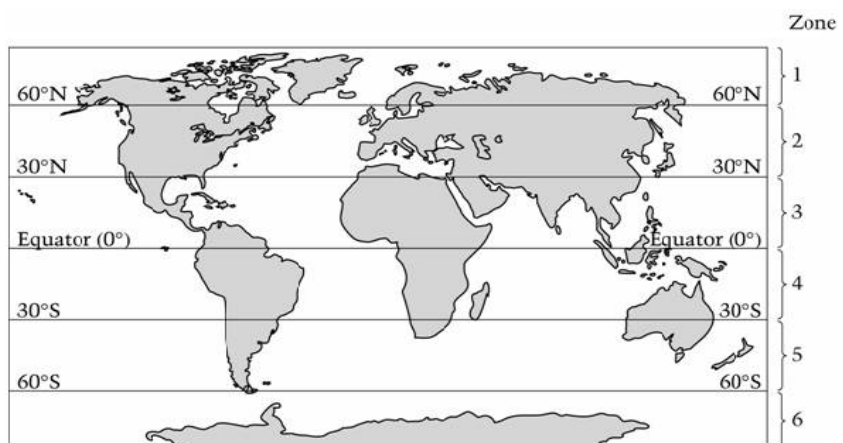

53. El Niño and La Niña

- A. both increase water temperatures in the eastern Pacific ocean
- B. both decrease water temperatures in the Atlantic and eastern Pacific ocean
- C. both increase water temperatures in the Gulf of Mexico
- D. produce changes in opposite directions in global temperatures

54. The greenhouse effect involves warming in the Earth's surface and the

- A. Stratosphere
- B. Troposphere
- C. Ionosphere
- D. Thermosphere

55. The graph below shows the average monthly temperatures for two cities, A and B, which are both located at 41° north latitude. Which statement best explains the difference in the average yearly temperature range for the two cities?

- A. City B is located in a different planetary wind belt.
- B. City B receives less yearly precipitation.
- C. City B has a greater yearly duration of insolation.
- D. City B is located near a large body of water.

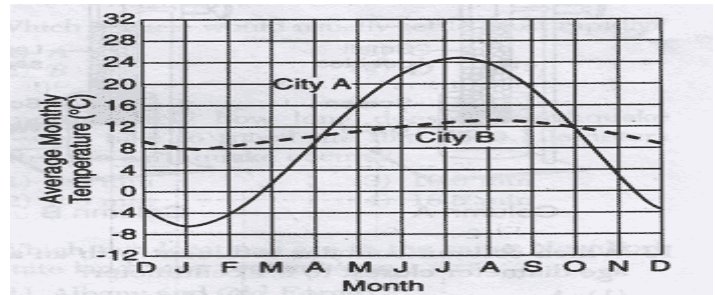

56. The largest source of anthropogenic greenhouse gases in our country is:

- A. electricity generation and industry
- B. electricity generation and transportation
- C. agriculture and transportation
- D. agriculture and electricity generation
- E. industry and agriculture

57. Reclamation reduces the impact of

- A. pollution
- B. mining
- C. farming
- D. waste

58. Rangelands may suffer from

- A. poor land management practices
- B. overgrazing by herd animals
- C. desertification
- D. compacted soil

59. The inter and intrastate roadways, local roads, transportation facilities, utility installations and services which are needed in our state and elsewhere to provide for the modern needs of a community are defined as :

- A. ecosystem services
- B. infrastructure
- C. planned developments
- D. urban enterprise zones

60. Maximum sustainable yield, ecosystem-based management and adaptive management are three approaches to

- A. infiltration zones
- B. natural resource management
- C. overharvesting
- D. salvage logging

The following is a graph of daily mean Dissolved oxygen levels taken during 2012 at Raritan River Manville NJ testing site.

Source:

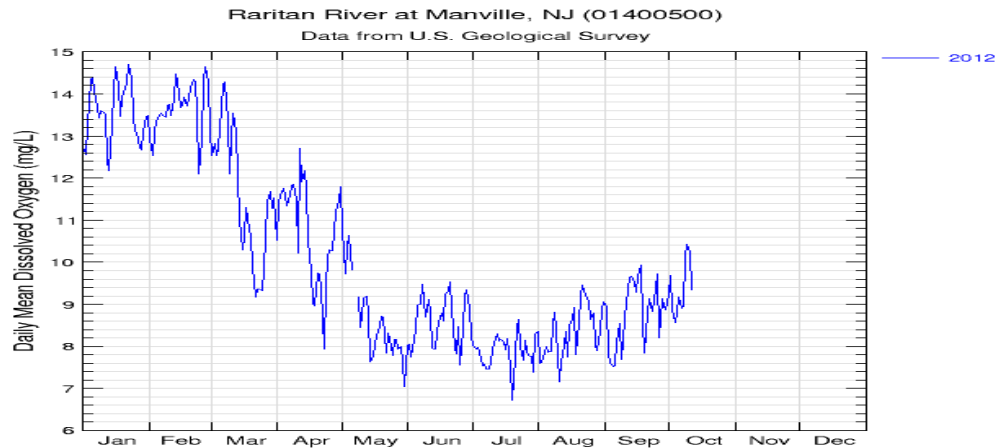

[http://nj.usgs.gov/cgi-bin/grapher/graph\\_by\\_yr.pl](http://nj.usgs.gov/cgi-bin/grapher/graph_by_yr.pl)

61. Based upon the graph above which statement below is NOT supported by the graph?
- Winter months with cold temperatures have decreased decomposition & increased D/O.
  - Winter months and snow melt have increased velocity, increasing D/O.
  - Summer temperatures resulted in a downward trend in D/O
  - April showers increased velocity thereby increasing D/O.
  - Trees were cut down along the river and stream bed, increasing sunlight and D/O.
62. Sometimes, data cannot be collected. What would the most likely reason be for the lack of data taken during late October through December 2012?
- Equipment failure
  - US Government shut-down
  - Hurricane Sandy and its after-math
  - None of the above
63. This winter season (2013-2014) has ranked among the top ten on record in terms of the amount of snowfall as of mid-February. Snow on the ground will do all of the following **except**:
- Melt when temperatures are high enough and enter storm drains
  - Infiltrate into recharge zones
  - Increase eutrophication
  - Result in a high spring water table
  - Sublimate into water vapor on sunny days
64. Increases in all of the following factors decrease D/O in rivers and streams **except**:
- velocity
  - altitude
  - Nutrient load and organic wastes
  - Temperature
  - Volume
65. Photosynthesis and time of day can impact dissolved oxygen levels because:
- photosynthesis increases during daylight hours
  - photosynthetic organisms can produce more oxygen at night
  - decomposers produce dissolved oxygen once dead organisms sink to the bottom at night
  - none of the above

66. Water that falls to Earth's surface may enter the groundwater by which process?
- A. Precipitation
  - B. Infiltration
  - C. Condensation
  - D. Evaporation
  - E. Transpiration

67. A well to produce water should be drilled into which layer?

- A. Zone of aeration
- B. Water table
- C. Permeable aquifer
- D. Impermeable aquifer

68. What environmental impact can a dam have on the area downstream from the dam?

- A. The land is flooded, destroying homes and farm crops
- B. Flooding is reduced
- C. Sediment builds up
- D. Large amounts of water are lost through evaporation
- E. Recreational areas are built up.

69. The graph below plots late afternoon temperature vs areas around a city. The profile below shows the effect of a heat island. All of the following sources can result in a heat island **except**:

- A. Waste heat from energy-utilizing processes
- B. Formation of a rain shadow effect
- C. Absorption of sunlight and energy storage of urban surfaces
- D. Reduced urban ventilation due to surface roughness

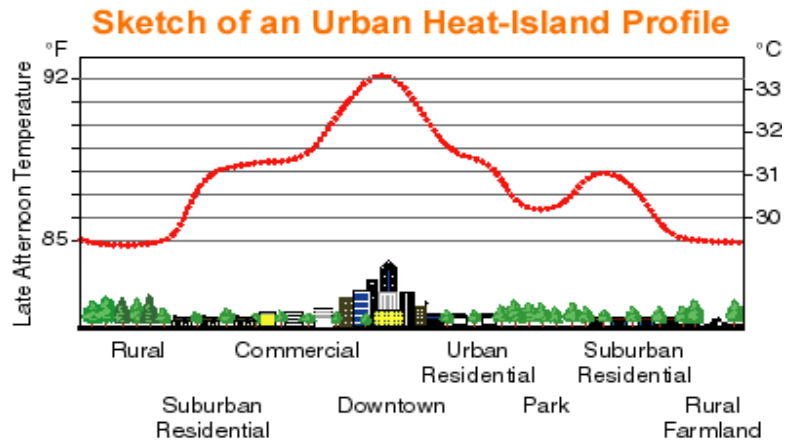

70. Barnegat Bay, Sandy Hook and even the Chesapeake Bay have experienced a recent decline in fish populations. Many of the typical native species have been declining and other species have proliferated such as jellyfish. Jellyfish can tolerate lower D/O levels. Which environmental problem might be associated with the increase in jellyfish?

- I. Habitat destruction
  - II. Power generation plants
  - III. Heavy metals
  - IV. Eutrophication
- A. I and II      B. II and III      C. III and IV only      D. I and IV only

NEW JERSEY SCIENCE LEAGUE

Environmental Science Answer Key: **Green test.**

March 13, 2014 **Record the number correct.** (corrections)

1	B	15	D	29	B	43	B	57	B
2	D	16	B	30	A	44	C	58	E(All full)
3	C	17	E	31	A	45	A	59	B
4	D	18	A	32	D	46	D All full	60	B
5	A	19	B	33	D&B	47	E	61	E
6	D	20	C	34	C	48	D	62	C
7	E	21	C	35	A	49	C	63	C
8	C	22	A	36	C	50	A	64	A
9	E	23	D	37	D	51	D	65	A
10	B	24	D	38	B (All full)	52	B	66	B
11	A	25	B	39	A (All full)	53	D	67	C&B
12	D	26	B	40	D(E)	54	B	68	B
13	C	27	C	41	A	55	D	69	B
14	C	28	B	42	C	56	B	70	D

**NJSL Environmental Science Exam**

**April 2014**

Choose the answer that best completes the statements or questions below and fill in the appropriate response on the form. If you change an answer, be sure to completely erase your first choice. Please PRINT your name, school, area, and which test you are taking onto the scan-tron.

**RENEWABLE SOURCES**

The production of petroleum in the US peaked in 1971. Natural gas production from traditional US basins appears to have reached a plateau. Among the alternatives to the use of fossil fuels is solar power. A person uses about  $10^{21}$  Joules of energy a year, which the sun generates in one hour.

1. Which of the following features of the use of solar power is not true?  
“Energy through the use of sunlight \_\_\_\_\_.”
  - A. has wide availability
  - B. is in large supply
  - C. is non-renewable
  - D. in some uses, can be locally non-polluting
  - E. will require extensive storage in order to be widely used
  
2. More solar energy reaches the equatorial regions than the polar regions because the equatorial regions
  - A. are covered by a greater area of land.
  - B. have more vegetation to absorb sunlight.
  - C. have days with more hours of light.
  - D. receive sun rays closest to vertical.
  
3. Composting is a process that produces
  - A. useful plastic products
  - B. a nutrient-rich soil conditioner
  - C. manure
  - D. lower-grade paper products
  - E. materials used in construction
  
4. Geothermal energy, a possible energy resource, is based on which phenomenon?
  - A. There are concentrations of heat in some places of Earth’s crust.
  - B. Earth’s internal energy heats its surface more than the Sun does.
  - C. Heat energy from the Sun penetrates deep into Earth.
  - D. Human activity is the largest source of heat energy on Earth.

New Jersey, the most densely populated state in the nation, generates much waste including animal manures and food wastes, that could be used in the process of Biogas Recovery. Using this waste to create energy would provide the added benefit of reducing the amount of landfill space needed in the state. In addition, the process creates a byproduct of nutrient-rich fertilizer that could be used by farmers. As a result of the Biofuels Group meetings at the NJDA, Rutgers University conducted a Biomass Inventory that catalogued all the available New Jersey biomass from crops, wastes and other sources that could be turned into energy. The Rutgers Eco-complex in Bordentown, NJ is a model of sustainable practice. It has a bioreactor landfill which collects gas to generate electricity to run a hydroponic greenhouse. On site vehicles are powered by biofuels and biomass is not discarded but rather converted in a bio-digester.

Figure 2: Components and Products of a Biogas Recovery System.

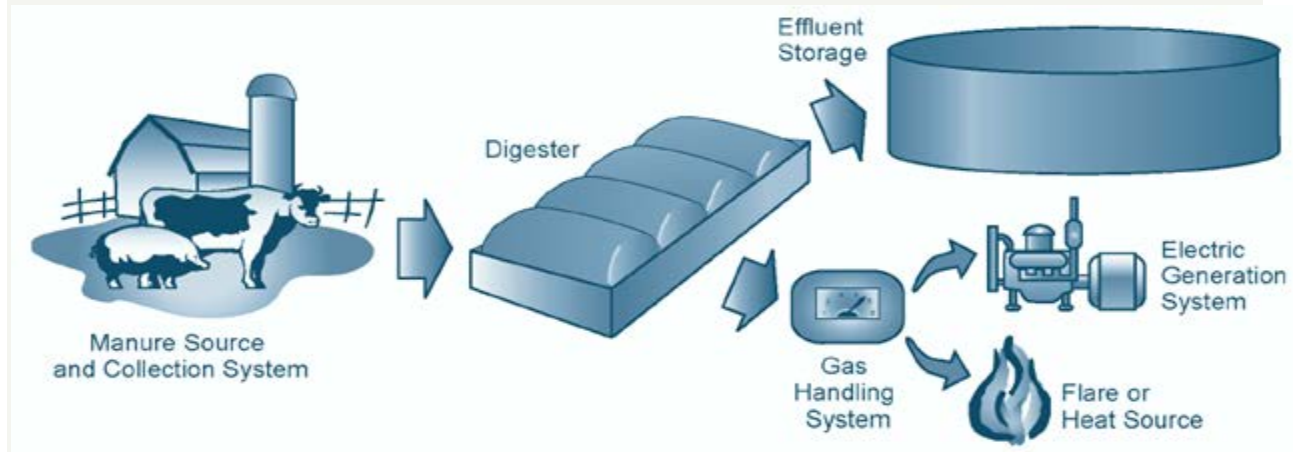

Source: [Managing Manure with Biogas Recovery Systems: Improved Performance at Competitive Costs](#). EPA AgSTAR

Rising energy prices, broader regulatory requirements, and increased competition in the marketplace are causing many in America's agricultural livestock sector to consider anaerobic digestion of animal wastes. They view the technology as a way to cut costs, address environmental concerns, and sometimes generate new revenues by processing other bio-degradable products such as food processing waste and table scraps. The key by-products of anaerobic digestion include methane gas, potting soils and purified water. The primary component, methane gas, can be used to fuel a variety of cooking, heating, cooling, and lighting applications, as well as the generation of electricity. Capturing and using the methane also precludes its release into the atmosphere, where it is 20 times more damaging to the ozone layer than carbon dioxide.

Anaerobic Digesters Image source: <http://www.e-inst.com/biomass-to-biogas/>

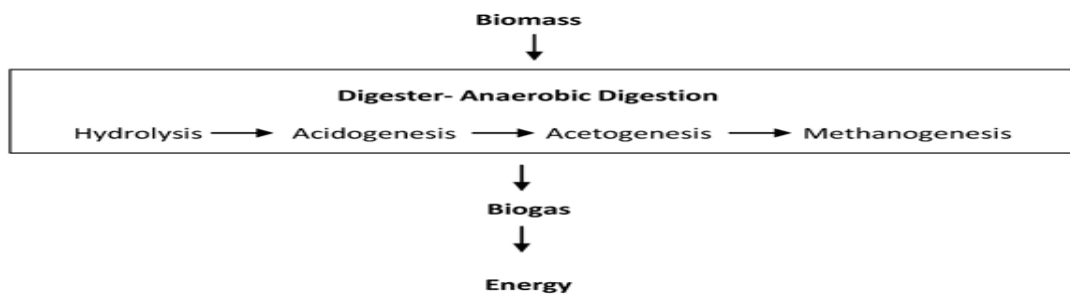

5. Simple biomass techniques in developing nations use which of the following products to produce electricity or heat?

- A. wood and charcoal
- B. manure
- C. plant or crop residue
- D. B and C
- E. all of the above

6. Which of the following is NOT a drawback for using biogas mass for the production of energy?:

- A. Plants used for fuel can be grown on marginal land
- B. Causes increased erosion & water pollution in deforested areas.
- C. Can produce air pollution
- D. May require destruction of habitat /biodiversity for fuel wood

7. Which of the following are benefits of using solid biomass in an anaerobic digester?
- I. It captures methane gas
  - II. Converts animal waste into a usable product
  - III. Prevents animal waste from run-off getting into waterways and polluting the water and/or groundwater true
  - IV. Animal waste could be used to replenish soil nutrients
- A. I only      B. I and II only      C. II and III only      D. I, II, III, IV.
8. In which of the following renewable power plants would the availability of power be least reliable ?
- A. Solar power plant
  - B. Wind energy
  - C. Tidal power plant
  - D. Geothermal power plant.

**CropCorp** is a new corporation with the mission of developing new biofuels. You have been hired as a consultant to manage its newly acquired farm. You must decide which crop will most efficiently transform sunlight into a product that can be used to make a biofuel. You want to choose a crop that will make the most efficient use of space and resources (land, fertilizer, money). The farm you are planning for is located in central New Jersey, where the soil is a mix of sand, clay, and organic material with some stone and gravel. The land is flat with a 2-acre pond and 100 acres of forest that can be used for logging. One acre of land is approximately the size of a football field. All alternative fuel decisions have environmental and economic costs that must be considered. CropCorp would like you to recommend which crop, corn or switch grass, should be planted on the new farm.

Assuming the technology is developed for using switch grass as a vehicle fuel. Answer the following questions based upon the information in the table below.

**Figure 1 - RENEWABLE SOURCES OF ENERGY** Relevant Data Regarding Corn & Switch Grass Crops

	<b>Corn</b>	<b>Switch grass</b>
Approximate number of vehicles Using this fuel type	4 million	0 ( Note: Technology is still being developed )
Approximate # of working farms	300,000	100
Minimum temperature	32 °F	42 °F
After-harvest regrowth rate	None	Moderate
Other uses for crop	Seed, food, animal feed, sweetener, starch	Decorative landscaping
Precipitation range	20–50 inches/year	12–60 inches/year
Soil textures	Medium	Coarse, fine, & medium
Harvest per acre (average)	3.5 tons/acre	11.5 tons/acre
Fuel per acre (in GJ)	10.15 GJ/acre	26.45 GJ/acre
Part of plant converted to biofuel	Grain	All parts
Cost per acre of production	\$100–150/acre	\$75–100/acre

GJ – one billion joules, which are units of energy used to measure energy content



Use the data table above for questions 9, 10, and 11. The table compares the production and use of corn and switch grass.

9. Which choice below does not contribute to the cost of the production of corn?
- A. Cost per acre
  - B. Other uses
  - C. Harvest per acre
  - D. Fuel per acre
10. Which of the following factors indicate that switch grass has a greater “zone of tolerance”?
- A. Minimum temperature
  - B. Cost per acre
  - C. Precipitation range
  - D. None of the above
11. Which factor below does **not** show that switch grass is a better bio mass than corn?:
- A. Minimum temperature.
  - B. Cost per acre, harvest per acre
  - C. Part of plant converted to biofuel and soil textures
  - D. After-harvest regrowth rate

Atlantic City, NJ is a proposed site for the first NJ off-shore wind farm. Wind farms located off-shore are an increasingly attractive alternative energy source.

12. All of the following are **benefits** of off-shore wind turbines **except**:
- A. Produce no air pollution
  - B. Minimal habitat destruction
  - C. Has the full support of citizens with beach front property
  - D. Renewable energy sources cost less over long-term than oil, gas and coal.
13. Which statement about wind turbines is not true?
- A. Turbines are unsightly, sound and vibration is annoying
  - B. Affect migratory path of birds and bats
  - C. The manufacture and transport of wind towers generate carbon dioxide, CO<sub>2</sub>.
  - D. Wind farms in agricultural areas, destroys the habitat of the plants and animals in the area.

NUCLEAR FISSION – Nuclear fission using a pressurized water reactor design is used at the Salem Nuclear plant in South Jersey. Nuclear fission is the process whereby a heavy nucleus captures a slow moving neutron and undergoes splitting into smaller daughter nuclei. American designed nuclear reactors use “fuel rods” that are about 4 or 5 % uranium 235. The daughter products of the fission are radioactive, continue to decay, give off heat and have a half-life of about 10,000 years. Control rods absorb neutrons & thereby control the number of neutrons available to cause fission. They are in the fuel rod reactor area. The farther into the core they are inserted, the more neutrons they absorb. When used or “spent” the fuel rods are removed from a core reactor. The spent fuel rods continue to emit both radiation, principally from the fission fragments, and heat. It is unloaded into a storage pond immediately adjacent to the reactor to moderate the reaction and allow the radiation levels to decrease. Spent fuel rods are usually stored in lead lined concrete pool structures where they are submerged in water to cool them down after removal from a reactor core. The water shields the radiation and absorbs the heat, which is removed by circulating the water to external heat exchangers. Used fuel is held in such pools for several months and sometimes many years. It may be transferred to naturally-ventilated dry storage on site after about five years.

14. How many electrons are in an atom of the electrically neutral isotope of <sup>235</sup>U<sub>92</sub>, uranium-235?
- A. 327
  - B. 235
  - C. 143
  - D. 92
  - E. 6

15. Which of the five materials below is used as a moderator in a nuclear reaction?  
A. water      B. steel      C. Boron      D. cadmium      E. aluminum

16. Which of the following organisms is the **first** to be adversely affected by thermal pollution in a stream or river near a nuclear plant?  
A. Trees along the bank      C. Large fish migrating up stream  
B. Insect larvae in the water      D. Birds drinking the water

For questions 17 – 20 use the information provided in the graph below. In 2002, a scientist conducted a study of the mercury concentrations in the livers of 26 dead whales. The age of each whale (to the nearest 10 years) was determined and the concentration of mercury in its liver was measured in mg/kg. The data gathered is shown below.

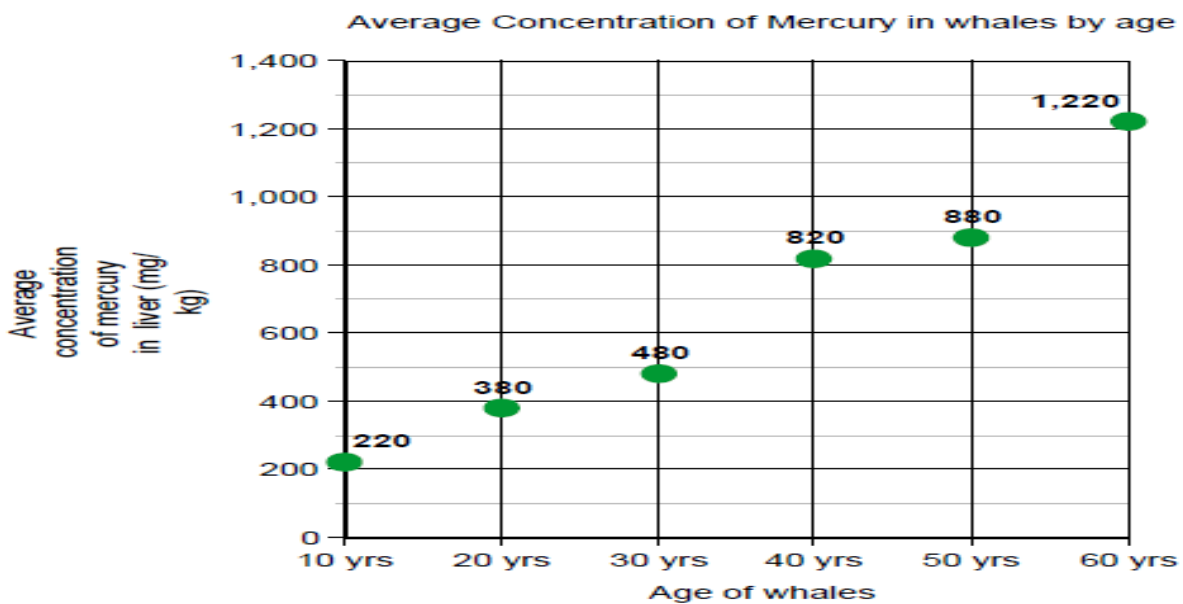

17. Which one of the following is the closest *estimate* of the average annual increase of mercury concentration in the whales?  
A. 10 mg/kg      C. 200 mg/kg  
B. 20 mg/kg      D. 1200 mg/kg
18. Which one of the following is the best explanation for the data?  
A. The mercury accumulated in the livers of the whales.  
B. Older whales absorb more mercury per annum than younger whales.  
C. The concentration of mercury in the water gradually increased with time.  
D. Older whales have more difficulty excreting mercury than younger whales.

19. In the country in which the study was conducted, some whale meat is still eaten by people. Which one of the following is likely to be the consequence of consuming large amounts of whale meat over a long period of time?

- A. indigestion
- B. breathing difficulties
- C. unpleasant taste of the meat
- D. mental and nervous system disorders

20. The form of mercury most likely to be involved in bioaccumulation is

- A. mercury salt.
- B. mercury vapor.
- C. methyl mercury.
- D. metallic (elemental) mercury.

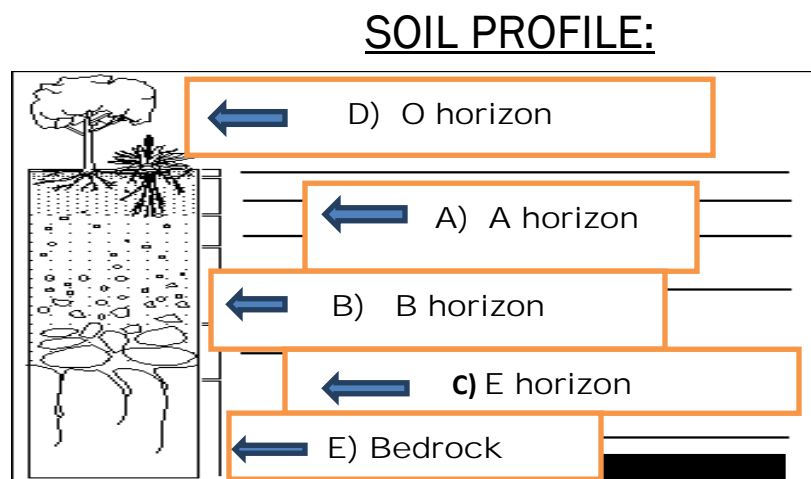

The letters on the soil profile above correspond to A, B, C, D, and E answer selections below. Indicate the letter which properly identifies the soil horizon described in questions 21 through 25. If you select letter C that means your answer is "E horizon."

- A. A horizon
- B. B horizon
- C. E horizon
- D. O horizon
- E. Bedrock

21. Silt and sand are concentrated here

22. Litter layer, mostly un-decayed materials

23. The deep, underlying non-soil materials

24. The layer where minerals that were leached out of layers above accumulate

25. A mixture of soil and detritus layer

Questions 26-30 refer to the following types of soil.

- A. Desert soil
- B. Grassland soil
- C. Tropical rain forest soil
- D. Pine forest soil
- E. Deciduous forest soil

- 26. Soil has a substantial organic layer, fire helps to break down plant material in this layer
- 27. Soil comprised of litter and humus; this soil is acidic due to the accumulation of needles
- 28. Soil is rocky, very dry, and contains almost no organic matter
- 29. Soil is acidic and contains very little organic matter despite large plant populations
- 30. Soil is rich in humus and partially decayed leaves

## WASTE

Waste Water Treatment Plants - Like the CCMUA - "Camden County Municipal Utility Authority" operate on a three step process to purify the wastewater. The three steps are listed in the drawing below. The plant treats waste water and storm water.

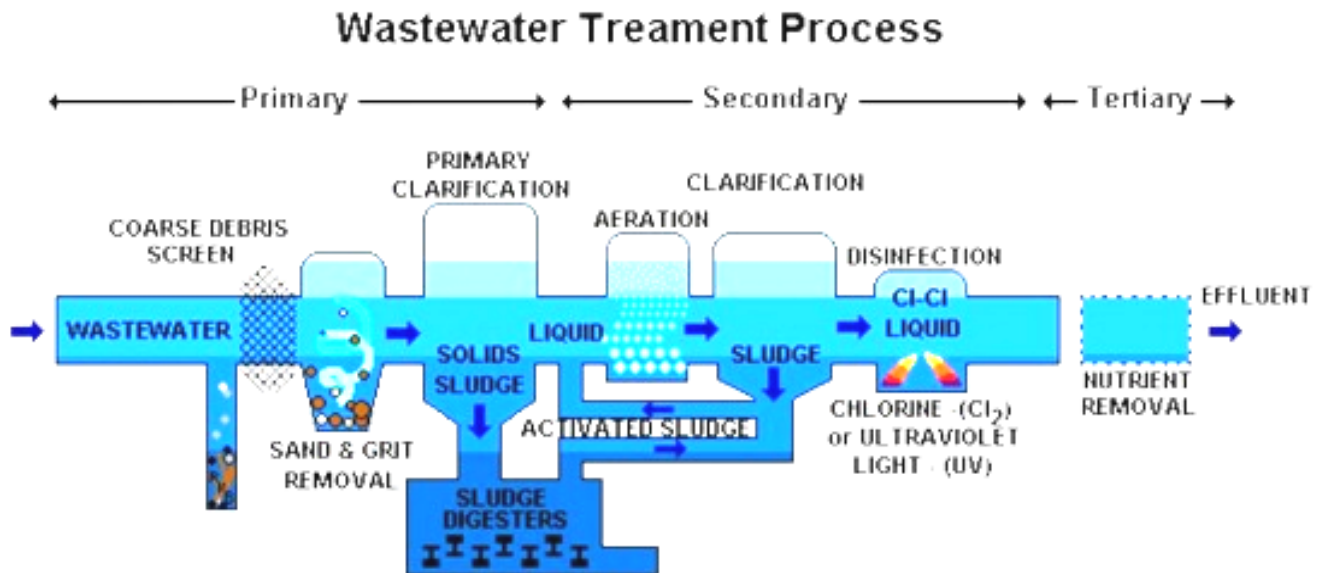

For the next three questions, 31, 32, and 33 use the diagram above.

- A. Primary Step
- B. Secondary Step
- C. Tertiary Step

- 31. If you were to flush a small object in a public water facility at which step would it stop?
- 32. During which step is oxygen added to the wastewater?
- 33. During which step would sodium hypochlorite (the active ingredient in household bleach), be added?

34. The terms used for water entering the waste treatment plant and leaving are:
- Grey water and processed water
  - Influent and effluent
  - Grey water and potable water
  - None of the above
35. The Camden plant is a “ duo system”. What are the two systems at work at this plant?
- It works for twice a day – daytime and night
  - It provides both clean water and natural gas
  - It treats both storm water and wastewater
  - It treats only septic systems but can treat it in two steps
36. The main product at this plant is clean water, which is piped back into the Delaware River. What is the main secondary product?
- bacteria
  - Chlorine
  - sludge
37. Which instrument below would be used to measure the turbidity of the water as it leaves the waste plant?
- pH meter
  - a scale
  - spectrophotometer
  - electron microscope
38. To ensure that all effluent discharge requirements are met, samples are routinely tested and the test results are supplied to the State regulators. Given modern daily habits, at approximately what time of day would you suspect the amount of residential grease and solids to be greatest?
- 7 am
  - Noon
  - 4 pm
  - 7 pm
39. Which method of solid-waste treatment would be best suited for neutralizing the acidic components of waste?
- Sanitary landfill
  - Discharge to sewers, streams, and rivers
  - Incineration
  - Chemical treatment
40. Acid deposition most severely effects amphibian species because amphibians
- do not care for their young
  - are not mammals
  - need to live in both terrestrial and aquatic habitats
  - seldom reproduce
41. Scrubbers are devices installed in smoke stacks to
- reduce the amount of materials such as SO<sub>2</sub> in the smoke they discharge
  - clean out the stack so smoke can move rapidly upwards
  - reduce the amount of sulfur in coal before it is burned
  - clean out the boilers for more efficient operation
  - reduce the amount of toxic ash produce

42. Acid rain and snow harm some areas more than other areas because certain areas
- A. have more bacteria in the soil than others
  - B. have less of an ability to neutralize the acids
  - C. are at a higher elevation than the unaffected areas
  - D. are closer to lakes than the unaffected areas
  - E. have more complex food webs than the unaffected areas

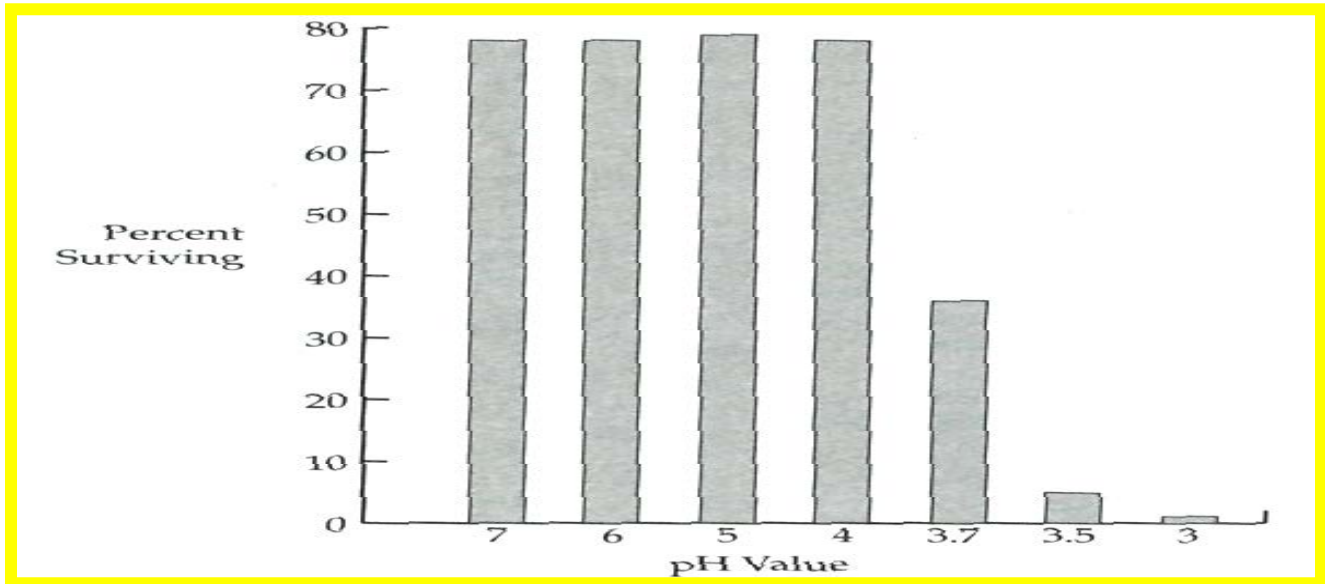

Questions 43-46 refer to the following passage & graph above. A scientist placed 100 fish eggs into each of seven solutions with different pH values. After 96 hours, the number of survivors was counted & converted into a percent. The percent surviving is given in the graph above.

43. Which of the pH values below best represents the LD<sub>50</sub> (LD<sub>50</sub> is lethal dose) in this experiment?
- A. 3.0
  - B. 3.5
  - C. 3.7
  - D. 4.0
  - E. 5.0
44. At what pH value do the least number of fish survive?
- A. 7.0
  - B. 4.0
  - C. 3.7
  - D. 3.5
  - E. 3.0
45. Which of the following best describes the goal of the above experiment?
- A. To test the hypothesis that the bigger the fish, the smaller the pH tolerance range.
  - B. To observe how many fish would hatch at different pH values.
  - C. To find out how many fish live in streams with different pH values.
  - D. To understand how acid rain affects life in streams.
  - E. To see what chemical is best at changing the pH of water.

46. The pH value is a measure of the
- amount of heavy metals in the water
  - BOD of the water
  - concentration of oxygen in the water
  - concentration of hydrogen ions in the water
  - depth the scientist can see under the water

47. In the United States the single largest component of home waste is
- glass
  - food scraps
  - paper
  - lawn and yard clippings

48. NJ has significant mercury deposition in lakes and streams. As such, the state has adopted very rigorous emission standards. The resulting installation of carbon injection control devices in 1995, significantly reduced mercury emissions from about 4,400 pounds per year in 1992 (lbs./yr.) to about 500 lbs./yr. in 1996. This drop represents what percentage reduction?
- ~ 50%
  - ~ 33%
  - ~95%
  - ~89%
  - None of these are correct

49. Over the next few years several styles of incandescent light bulbs will be phased out. They are being replaced by LED lights. The reason for the change is due to the 5% efficiency of incandescent light bulbs. If one joule of energy is used in an incandescent light bulb, then which of the following is produced?
- 1.05 joules of light energy
  - 1.05 joules of heat energy
  - 0.95 joule of light energy
  - 0.05 joule of light energy
  - 0.05 joule of heat energy

Questions 50-54 refer the following five age-structure pyramid shapes in the diagram to the right.

- A country that is growing slowly
- A country close to zero population growth
- A country that is losing many of its young to diseases like AIDS
- A rapidly growing population
- A country showing a population decline

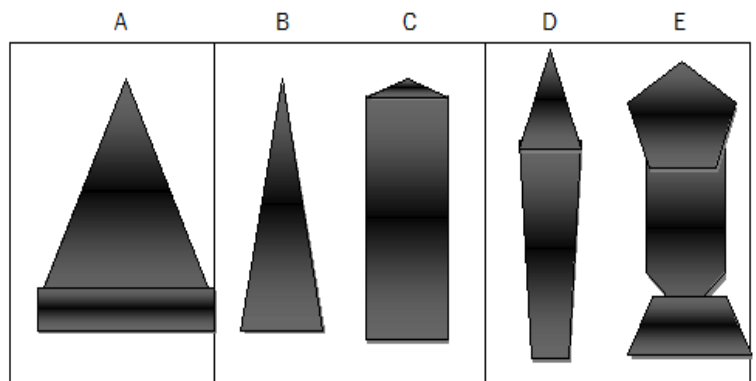

55. After ore is mined, the unusable part that remains is called
- Overburden
  - seam waste
  - leachate
  - tailings
56. Wastes stored in Love Canal contaminated the surrounding area by all of the following EXCEPT
- leeching into the ground water
  - fumes from burning the wastes
  - flowing in the sewers
  - runoff into a nearby stream
  - spilled drums of waste

57. A certain chemical having a concentration of 10 ppm in water means
- There are 10 molecules of the chemical in one million molecules of water.
  - There are 10 million molecules of the chemical in a 1-liter beaker.
  - There are 10 molecules of water in one million molecules of the chemical.
  - There are 10 molecules of the chemical in 10 million molecules of water.

58. What is an **advantage** of primitive or old-style landfills?
- They generate gases that can be recovered and used as fuel
  - Bad odors come from these landfills
  - Toxic wastes leach into ground water
  - Subsidence of the land after the landfill is filled
  - They create an eyesore in the neighborhood

**Waste** The Diamond Shamrock Plant in Newark NJ began operation in 1951 producing PCBs, DDT, dioxins, and other pesticides. Although the plant ceased to operate in the late 1970's, these chemicals are still in our waterways today. DDT along with PCB's, played a dominant role in the decline in NJ ospreys & other birds of prey in NJ. Before the introduction of DDT, NJ official estimates place the osprey count at 1,000 birds or 500 pairs. This dropped to 136 or 68 pairs by 1975. NJ banned DDT in 1968, added the osprey to the newly formed state endangered species list in 1974, and actively sought to reintroduce osprey to NJ waterways by building platform nests among other things. The return of ospreys to the Meadow -lands starting around 2006, is linked to the improved state of the Hackensack River, monitoring & preservation of the wetlands and cleanup of once-contaminated sites along the river which also included treatment of PCB's. (Basic PCB Shape; Chlorines can be substituted for any of the hydrogen atoms.)

59. Estimate the percentage decline in osprey from 500 pairs to the state estimates in 1975.
- 25%
  - 14%
  - 86%
  - None of these are correct

60. The general structure of PCBs ( $C_{12}H_7Cl_3$ ) is given at the right. Based on this structure PCBs are
- soluble in water
  - insoluble in water
  - acidic
  - basic

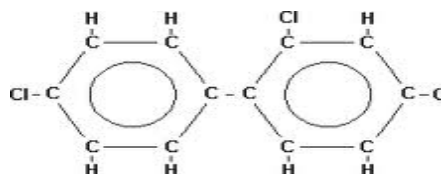

61. PCB concentration in organisms in NJ lakes
- increases as trophic level increases.
  - increases as population size increases.
  - decreases as trophic level increases.
  - decreases as population size increases.

PCB concentration in typical lake food chain	
herring gull	(124 ppm)
lake trout	(4.83 ppm)
small fish/ smelt	(1.94 ppm)
zooplankton	(0.025 ppm)
phytoplankton	( 0.0123 ppm)

62. Based on its chemical properties and structural formula above, high concentrations of PCBs should be found in what part of animal tissue?
- blood
  - muscle
  - fatty tissue
  - skin
  - bones



63. PCBs and DDT have been found in penguins eggs in the Antarctic. Which reason below best explains this observation?

- A. Chemicals used in one region of the Earth can circulate in the biosphere and affect organisms in distant regions.
- B. PCBs and DDT are toxic to birds, but it has no effect on developing embryos.
- C. PCBs and DDT are volatile and eventually make their way into the stratosphere.
- D. Because Penguins incubate their eggs on land, the eggs are exposed to DDT and PCBs.

64. Smelt have a greater PCB concentration than phytoplankton because

- I. smelt are larger than phytoplankton.
- II. smelt eat phytoplankton.
- III. smelt live longer than phytoplankton.
- IV. smelt are attracted to foods containing PCBs.

- A. I only
- B. I and II only
- C. I, II, and III only
- D. I, II, III, and IV

65. Why are PCBs still an environmental problem since they were banned 30 years ago?

- A. illegal manufacture of PCBs
- B. spontaneous formation of PCBs
- C. stability of PCB compounds
- D. long lives of lake organisms

66. Acid deposition on soil kills beneficial decomposers; this often leads to problems in:

- A. Sulfur cycling
- B. Phosphorus cycling
- C. Hydrologic cycling
- D. Nitrogen cycling
- E. Temperature cycling

67. An increase in sediment in surface water can be caused by

- A. Cultivating crop land
- B. Construction of buildings
- C. Grazing or Feeding lots
- D. All of the above

68. Particulate matter degrades air quality. Which of the following **does not** contribute to the release of particulates into the air?

- A. Re-vegetation
- B. Deforestation
- C. Urban sprawl
- D. Volcanic eruptions
- E. Auto exhaust

69. If a water body has a mat of green algae growing over its surface it is termed eutrophic.

Eutrophication can be caused naturally or by man. If the algae mat gets too thick the water body will

- A. Have a high dissolved oxygen and low biological oxygen demand
- B. Have a low dissolved oxygen and a high biological oxygen demand
- C. Have a low dissolved oxygen and a low biological oxygen demand
- D. Have a high dissolved oxygen and a high biological oxygen demand

NJ Orange Factory Radium Girls painted the dials of watches with radium to glow in the dark during the early 20<sup>th</sup> century (1917 to 1926) U.S. Radium Corporation extracted and purified radium from an ore called carnitite. This was used to create a paint which glowed in the dark. The U.S. Radium Corporation hired some women to perform various tasks including the handling of radium, while the owners and the scientists familiar with the effects of radium carefully avoided any exposure to it themselves; chemists at the plant used lead screens, masks and tongs. In Orange, NJ, women were employed at the NJ plant site to paint watch faces. They would lick the paint brushes to get a proper point on the brush in order to paint the tiny numerals on the watch dials. In doing so, they were exposed to high levels of radium. Five women known as the *Radium Girls*, filed a lawsuit and were awarded money for the damage to their health.

70. This case had all of the following effects:

- A. The right of individual workers to sue for damages from corporations due to labor abuse.
- B. Helped to establish a threshold for radium-induced cancers and introduce “occupational disease” labor laws
- C. Both A and B
- D. Neither A nor B

NEW JERSEY SCIENCE LEAGUE

Environmental Science Answer Key: **Green test.**

APRIL 2014 **Record onto the area record the # correct (Corrections)**

1	C	15	A	29	C	43	C	57	A
2	D	16	B	30	E	44	E	58	A
3	B	17	B	31	A	45	B	59	C
4	A	18	A	32	B	46	D	60	B
5	E	19	D	33	B	47	C	61	A
6	A	20	C	34	B	48	D	62	C
7	D	21	C(all full)	35	C	49	D	63	A
8	B	22	D	36	C	50	B	64	D(C)
9	B	23	E	37	C	51	C	65	C
10	C	24	B(all full)	38	A	52	E	66	D
11	A	25	A	39	D	53	A	67	D
12	C	26	B	40	C	54	D	68	A
13	D	27	D	41	A	55	D	69	B(All full)
14	D	28	A	42	B	56	B	70	C

