

7. Which of the following pairs contains unrelated items?
 a. eukaryote–animal cell b. ribosomes–protein
 c. cell wall–animal cell d. mitochondria–energy
8. Small lipids can pass directly through a cell membrane without going through a pore because
 a. they can dissolve in the lipid bilayer b. they are too large for the pores
 c. membranes allow all types of materials to pass through d. they are polar
 e. active transport must occur for this to happen
9. Nucleotides can be radiolabeled before they are incorporated into newly forming DNA and can therefore be assayed to track their incorporation. In a set of experiments, a student–faculty research team used labeled T nucleotides and introduced these into the culture of dividing human cells at specific times. Which of the following questions might be answered by such a method?
 a. How many cells are produced by the culture per hour?
 b. What is the length of the S phase of the cell cycle?
 c. When does the chromatin condense into chromosomes?
 d. How many picograms of RNA are made per cell cycle?
10. Knowing that insulin is a protein consisting of 51 amino acids, which process is most likely used to release insulin from pancreatic cells into the bloodstream?
 a. passive diffusion b. active transport c. endocytosis d. exocytosis
11. The functional group written as –COOH is called
 a. carbonyl group b. hydroxyl group c. amino group
 d. ketone group e. carboxyl group
12. Proteins that are to be synthesized and then secreted pass through what series of organelles?
 a. nucleus→ Golgi body→ rough E.R→ vesicles→plasma membrane
 b. nucleus→ rough E.R → Golgi body → vesicles→plasma membrane
 c. nucleus→ rough E.R→ lysosomes→plasma membrane
 d. nucleus→ vesicles →rough E.R→ Golgi body →plasma membrane
 e. nucleus→ Golgi body→ vesicles → rough E.R →plasma membrane

13. Use the figure to the right for questions 13 and 14. The unlettered circle at the top of the figure shows a diploid nucleus with four chromosomes that have not yet replicated. There are two pairs of homologous chromosomes, one long and the other short. One haploid set is black and the other is gray. The chromosomes in the unlettered circle have not yet replicated. The circles labeled A–E show various combinations of these chromosomes. Which is the correct chromosomal conditions for the prometaphase of mitosis.

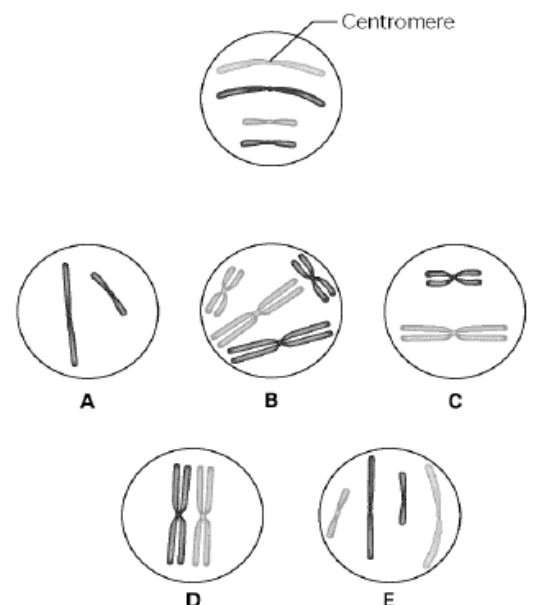

- a. A b. B c. C d. D e. E

14. What is the correct chromosomal condition for one daughter nucleus at telophase of mitosis?
 a. A b. B c. C d. D e. E
15. Which of the following enables plant cells to achieve enough structural rigidity to support the overall plant?
 a. the stacking of thylakoids within the chloroplasts
 b. the osmotic pressure within the central vacuole
 c. the facilitated diffusion of proteins across the plasma membrane
 d. the matrix of polysaccharides in the cytoskeleton
16. Which statement is true regarding osmosis and diffusion in a living cell?
 a. The movement of solvent occurs from a hypotonic solution to a hypertonic solution
 b. The net movement from a hypertonic to a hypotonic solution involves the movement of solutes only
 c. Once isotonic conditions result, the movement of the solutes and the solute stop
 d. The net movement of the solvent is achieved by receptor-mediated endocytosis
17. One difference between a plant and animal cell is
 a. only plant cells have chloroplasts while only animal cells have mitochondria
 b. only plant cells have vacuoles
 c. only animal cells have nucleoli
 d. only animal cells have plasma membranes
 e. animal cells form a cleavage furrow when they divide

18. Which phrase best describes an organ system?
 a. group of specialized cells that forms organs
 b. group of cells that differentiates at the same rate
 c. group of tissues that performs a function
 d. group of organs that work together

19. To the right is a sketch of an animal cell. Which one of the following statements is correct?
 a. Structure A detoxifies poisons in the cell
 b. Structure B packages proteins for export
 c. Structure C synthesizes RNA
 d. Structure D consists of cytoplasm

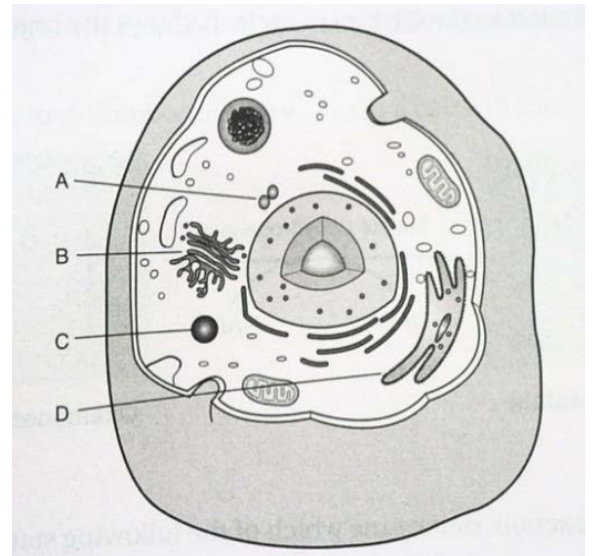

20. Which bond or interaction would be the most difficult to disrupt when compounds are dissolved in water?
 a. ionic bond b. covalent bond c. Van der Waals interactions d. hydrogen bonds

21. Which of the following functional groups contain nitrogen?
 a. sulfhydryl b. hydroxyl c. methyl d. carboxyl e. amino
22. Homeostasis in humans is regulated by the action of
 a. the nervous system, only b. both the nervous and endocrine systems
 c. the endocrine system, only d. neither the nervous nor the endocrine system
23. Which of the following correctly lists the levels of organization from least complex to most complex?
 a. cellular, tissue, chemical system, organ, organism
 b. chemical, cellular, tissue, organ, system, organism
 c. tissue, cellular, chemical, organ, system, organism
 d. chemical, tissue, cellular, system, organ, organism
 e. organism, system, organ, tissue cellular, chemical
24. What two biological variables affect how well an enzyme functions in a body cell?
 a. sunlight and minerals b. temperature and sunlight
 c. pH and time of last meal d. temperature and pH
25. What is the monomer of a polypeptide (protein)?
 a. nucleotide b. amino acid c. glycerol d. monosaccharide

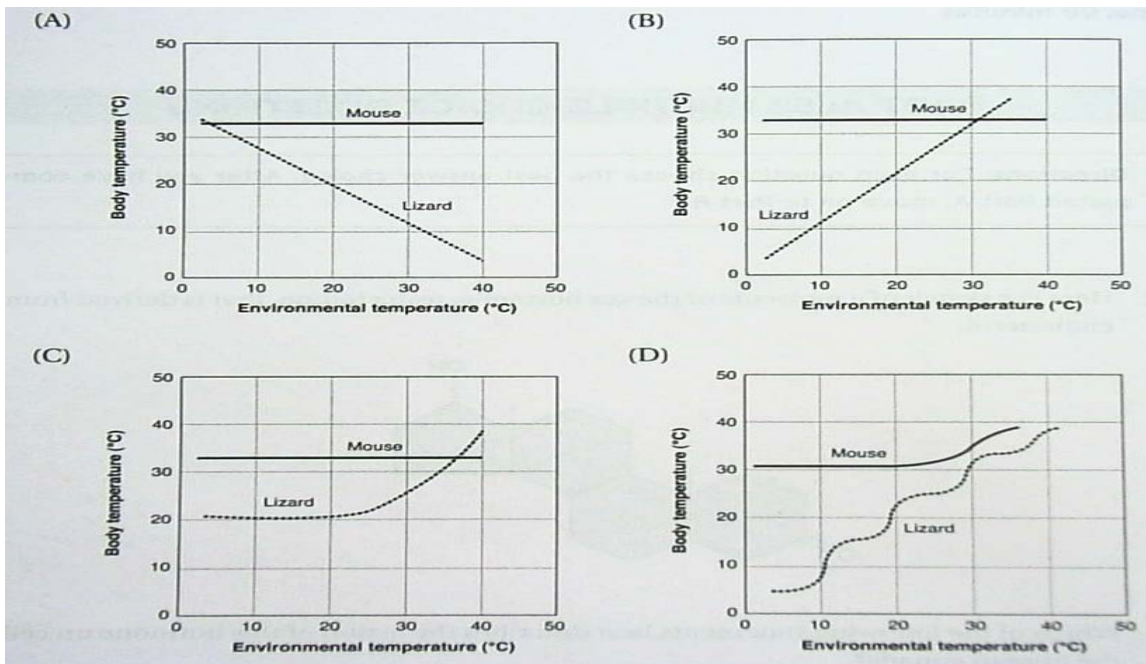

26. Mice are mammals. As such, they are endotherms. They maintain internal heat metabolically. A lizard is an ectotherm and gains its body heat from the environment. Which graph above most accurately depicts this situation?
27. Which property of water best explains capillarity?
 a. Water has a very high specific heat. c. Water is a polar molecule.
 b. Water is most dense at 4°C. d. Water can dissolve salt.

28. In living organisms lipids function mainly as
- sources of stored energy and transmitters of gene information
 - catalyst of chemical reactions and components of cellular membranes
 - sources of stored energy and components of cellular membranes
 - transmitters of genetic information and catalyst of chemical reactions
29. In a cold environment, an ectotherm is more likely to survive an extended period of food deprivation than would an equally sized endotherm because the ectotherm
- maintains a higher basal metabolic rate
 - expends more energy per kg of body mass than does the endotherm
 - invests little energy in temperature regulation
 - metabolizes its stored energy more readily than the endotherm
30. During which phase of mitosis does the nuclear membrane disintegrate?
- prophase
 - anaphase
 - metaphase
 - telophase
 - interphase
31. Some mammals control their body temperature by sweating. Which property of water is most directly responsible for the ability of sweat to lower body temperature?
- water's change in density when it cools
 - water's ability to dissolve salt
 - the release of heat by the formation of hydrogen bonds
 - the absorption of heat by the breaking of hydrogen bonds
32. In a single molecule of water, two hydrogen atoms are bonded to a single oxygen atom by
- hydrogen bonds.
 - nonpolar covalent bonds.
 - polar covalent bonds.
 - ionic bonds.
33. If a 0.9% NaCl were isotonic to a cell, then
- 0.9% would also be hypotonic
 - 0.9% would also be hypertonic
 - 1.0% would be hypertonic
 - 1.0% would be hypotonic
 - 0.1% would be hypertonic
34. Which of the following pairs does NOT represent a correct structural relationship?
- fat; lipid
 - starch; polysaccharide
 - starch; carbohydrate
 - sugar; carbohydrate
 - enzyme; lipid
35. When a potassium ion (K^+) moves from the soil into the vacuole of a cell on the surface of a root, it must pass through several cellular structures. Which of the following correctly describes the order in which these structures will be encountered by the ion?
- plasma membrane > primary cell wall > cytoplasm > vacuole
 - secondary cell wall > plasma membrane > primary cell wall > cytoplasm > vacuole
 - primary cell wall > plasma membrane > cytoplasm > vacuole
 - primary cell wall > plasma membrane > lysosome > cytoplasm > vacuole

36. Substances transported by facilitated diffusion
- move passively through specific channels from an area of greater concentration to one of lower concentration
 - are limited to solvents
 - must have movements coupled to those of other substances
 - may flow to a region of higher concentration by the expenditure of energy
 - are restricted to only one direction through the membrane

37. Based on the figure below, which of these experimental treatments would increase the rate of sucrose transport into the cell?

- decreasing extracellular sucrose concentration
- decreasing extracellular pH
- decreasing cytoplasmic pH
- adding an inhibitor that blocks the regeneration of ATP

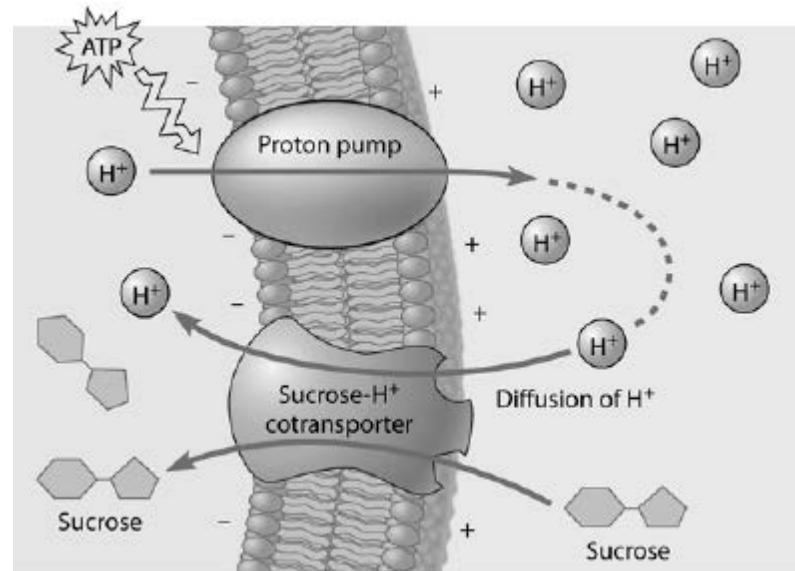

38. A patient has had a serious accident and lost a lot of blood. In an attempt to replenish body fluids, distilled water—equal to the volume of blood lost—is transferred directly into one of his veins. What will be the most probable result of this transfusion?
- It will have no unfavorable effect as long as the water is free of viruses and bacteria.
 - The patient's red blood cells will shrivel up because the blood fluid has become hypotonic compared to the cells
 - The patient's red blood cells will swell because the blood fluid has become hypotonic compared to the cells.
 - The patient's red blood cells will shrivel up because the blood fluid has become hypertonic compared to the cells.
39. A carbon skeleton is covalently bonded to both an amino group and a carboxyl group. When placed in water it
- would function only as an acid because of the carboxyl group.
 - would function only as a base because of the amino group.
 - would function as neither an acid nor a base.
 - would function as both an acid and a base.

Questions 40-42. Use the following organic structural formulas for questions 40 through 42.

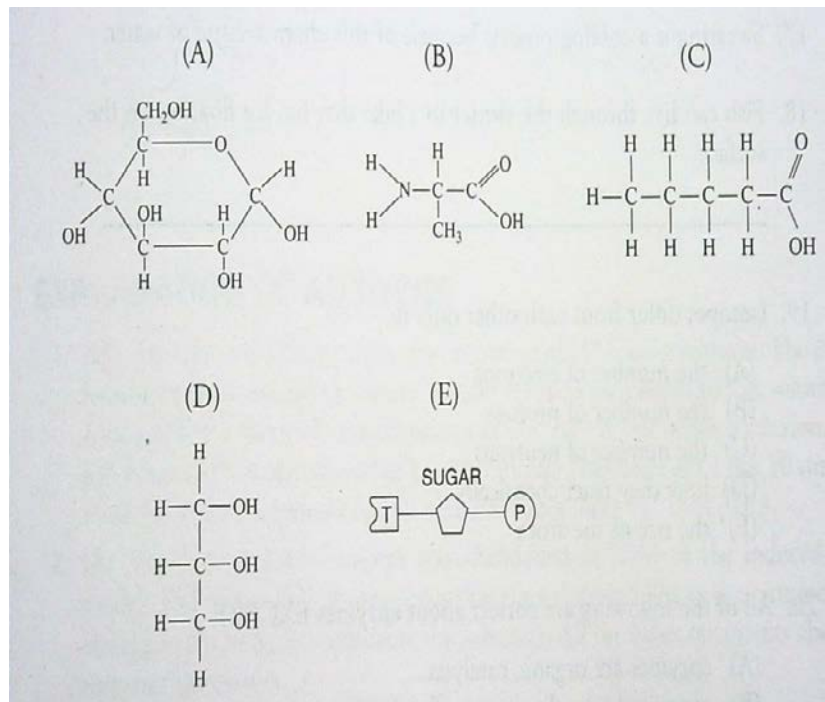

40. Which choice is a monosaccharide?
41. Which molecule can be incorporated into starch?
42. Which is an important part of protein?
43. A chemist wishes to make an organic molecule less acidic. Which of the following functional groups should be added to the molecule in order to do so?
 - a. carboxyl
 - b. sulfhydryl
 - c. hydroxyl
 - d. amino
44. An enzyme that digests proteins cannot digest carbohydrates because
 - a. proteins will change the chemical nature of the enzyme, making it inert
 - b. the enzyme must digest carbohydrates first, since proteins consume enzymes
 - c. the enzyme is specific in regards to what substrate it can act upon
 - d. proteins and carbohydrates are located in different parts of the body
45. The pH scale is known as a logarithmic scale. This means that an increase in _____ unit(s) is actually a _____ increase in concentration.
 - a. one, two-fold
 - b. one, ten-fold
 - c. ten, twofold
 - d. ten, one-fold

46. Which curve(s) on the graphs below represent the temperature and pH profiles of an enzyme taken from a bacterium that lives in a mildly alkaline hot springs at temperatures of 70°C or higher?

- a. curves 3 and 4
- b. curves 2 and 4
- c. curves 2 and 5
- d. curves 3 and 5

47. Which temperature and pH profile curves on the graphs were most likely generated from analysis of an enzyme from a human stomach where conditions are strongly acid?

- a. curves 1 and 4
- b. curves 1 and 5
- c. curves 2 and 4
- d. curves 2 and 5

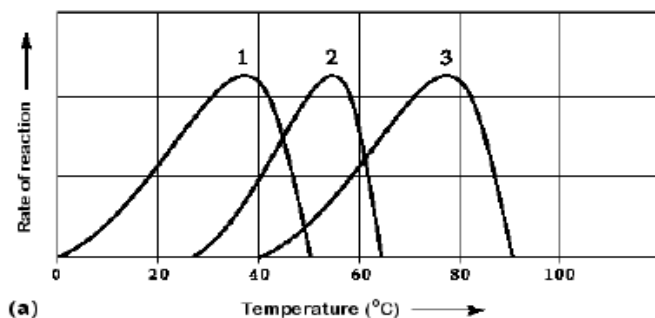

(a)

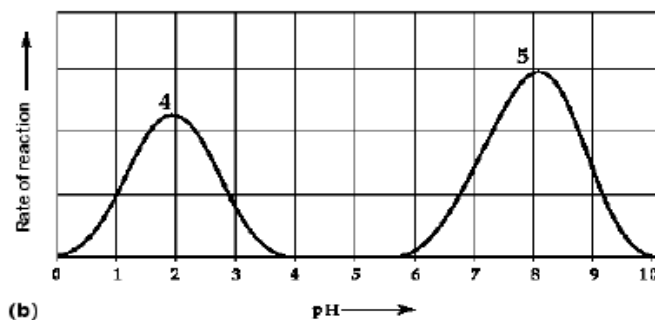

(b)

48. Based on your knowledge of the polarity of water molecules, the solute molecule depicted here is most likely

- a. positively charged
- b. negatively charged
- c. without charge
- d. hydrophobic.

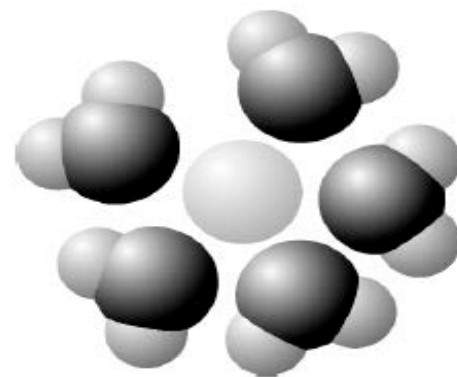

49. One of the buffers that contribute to pH stability in human blood is carbonic acid (H_2CO_3). Carbonic acid is a weak acid that, when placed in an aqueous solution, dissociates into a bicarbonate ion (HCO_3^{-1}) and a hydrogen ion (H^+). Thus,

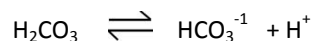

If the pH of the blood increases, one would expect

- a. a decrease in the concentration of H_2CO_3 and an increase in the concentration of HCO_3^{-1} .
- b. an increase in the concentration of H_2CO_3 and a decrease in the concentration of HCO_3^{-1} .
- c. a decrease in the concentration of HCO_3^{-1} and an increase in the concentration of H^+ .
- d. an increase in the concentration of HCO_3^{-1} and a decrease in the concentration of OH^- .

Questions 50-51.

A tissue or cells can be mashed in a blender to form a liquid homogenate and then spun in an ultracentrifuge at high speeds to separate it into layers based on differences in density. The densest cell organelles settle to the bottom of the tube, forming a pellet. The supernatant, the liquid above the pellet which contains less dense organelles, can be poured off and respun. In this way, cell organelles can be isolated. A homogenate of human tissue was processed and spun in this way. See the diagram below.

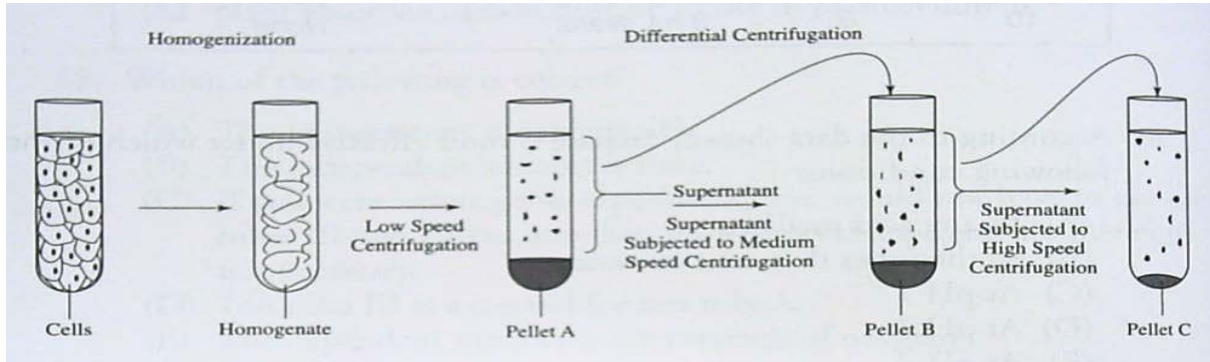

50. Pellet B was found to have the highest rate of oxygen uptake compared with the other pellets. Which organelles did it contain?

- a. Ribosomes
- b. Mitochondria
- c. Vacuoles
- d. Golgi
- e. Nuclei

51. Pellet C was analyzed and found to consist of high concentrations of RNA compared with the other pellets. Which organelles did it contain?

- a. Ribosomes
- b. Mitochondria
- c. Vacuoles
- d. Golgi
- e. Smooth Endoplasmic reticulum

52. Cytokinesis usually, but not always, follows mitosis. If a cell completed mitosis but not cytokinesis, the result would be a cell with

- a. a single large nucleus
- b. high concentrations of actin and myosin
- c. two abnormally small nuclei
- d. two nuclei
- e. two nuclei but with half the amount of DNA

53. A scientist isolated pieces of plasma membrane from an animal cell and put them in an apparatus so that the membrane separated two reservoirs of distilled water. When she added a dilute solution of acetic acid to one side (side A) of the membrane, the pH of the solution on the other side (side B) did not change. She then ground up a culture of animal cells, filtered out the organelles and bits of membrane, and added this cell extract to side A. The pH of the solution in side B then dropped. What is the most reasonable explanation for the drop in pH in side B?

- a. The cell extract contained lipids that dissolved in the membrane
- b. The cell extract caused the acetic acid to dissociate
- c. Protons moved across the membrane by diffusion
- d. Protons moved across the membrane by passive transport
- e. Protons moved across the membrane by active transport

54. A pharmaceutical company hires a chemist to analyze the purity of the water being used in its drug preparations. If the water has been deionized, then distilled the chemist would expect to find

- a. only H^+ ions and OH^- ions
- b. only H_2O molecules and H^+ ions
- c. only H_2O molecules and OH^- ions
- d. only molecules of H_2O
- e. only H_2O molecules, OH^- ions and H^+ ions

55. In the lock-and-key model of enzyme function shown below, what is happening in step 2?

- a. The catalyzed reaction is releasing a product.
- b. The active sites are restructuring the enzyme.
- c. The enzyme is causing new bonds to form between the substrates.
- d. The substrates are in the process of binding to the enzyme.

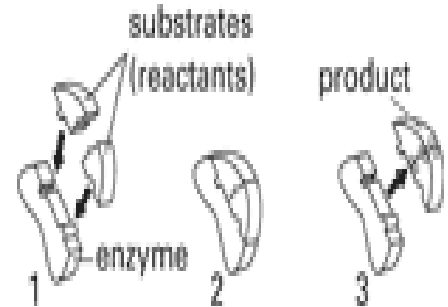

56. Which statement most accurately describes mitotic cell division in plant and animal cells?

- a. the process of cell division is exactly the same in plant and animal cells
- b. the daughter cells are genetically identical to the original cell in both plants and animals
- c. most plant cells use centrioles for cell division, but most animal cells do not
- d. the walls of the plant cell pinch in to enclose the new cell, but the membranes of animal cells do not

57. Colchicine is a drug that inhibits the polymerization of tubulin molecules into microtubules. Therefore, this drug would have the greatest potential impact on

- a. osmosis
- b. DNA synthesis
- c. mitosis
- d. cell growth (enlargement of a cell)

58. As a result of mitosis, each new cell has:

- a. twice as many chromosomes as its parent cell
- b. half as many chromosomes as its parent cell
- c. four times as many chromosomes as its parent cell
- d. the same number of chromosomes as its parent cell.

59. Which of the following statements describes an example of active transport?

- a. Glucose is transported across some membranes by carrier proteins down a concentration gradient.
- b. Freshwater protists such as amoeba and paramecia have contractile vacuoles that pump out excess water.
- c. Countercurrent exchange in the capillaries of fresh gills enables fish to absorb large amounts of oxygen from the surrounding water where oxygen levels are low.
- d. A red blood cell will lyse (burst) if placed into a hypotonic solution because large amounts of water flood into the cell.

60. Mitosis is represented by which Roman numeral?

- a. I
- b. II
- c. III
- d. IV
- e. V

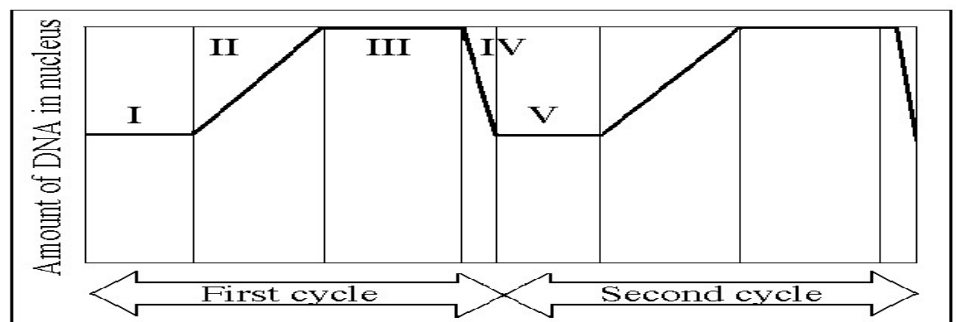

League Blue Test
Biology I Answer Key

Date: January 2014

1	D	16	A	31	D	46	D
2	D	17	E	32	C	47	A
3	A	18	D	33	C	48	A
4	D	19	B	34	E	49	A
5	C	20	B	35	C	50	B
6	A	21	E	36	A	51	A
7	C	22	B	37	B	52	D
8	A	23	B	38	C	53	E
9	B	24	D	39	D	54	E
10	D	25	B	40	A	55	C
11	E	26	B	41	A	56	B
12	B	27	C	42	B	57	C
13	B	28	C	43	D	58	D
14	E	29	C	44	C	59	B
15	B	30	A	45	B	60	D

NJSL Biology I Exam Feb 13, 2014

Choose the answer that best completes the statements or questions below and fill in the appropriate response on the form. If you change an answer, be sure to completely erase your first choice. Please PRINT your name, school, area, and which test you are taking onto the scan-tron.

1. Genetic engineers construct recombinant DNA molecules using two enzymes: restriction endonuclease and DNA ligase. What do these two enzymes do?
 - a. They catalyze different reactions; restriction endonuclease joins fragments into larger molecules; DNA ligase hydrolyses DNA into smaller fragments
 - b. They catalyze different reactions: restriction endonuclease hydrolyses DNA into smaller fragment; DNA ligase joins fragments into larger molecules

- c. They catalyze different hydrolysis reactions; restriction endonuclease hydrolyses bacterial plasmid DNA; DNA ligase hydrolysis DNA from eukaryotic cells.
- d. They both join fragments of DNA into larger molecules

2. In humans, PKU (phenylketonuria) is a disease caused by an enzyme dysfunction at step A in the following simplified reaction sequence, and AKU (alkaptonuria) is due to an enzyme inefficiency in one of the steps summarized as step B.

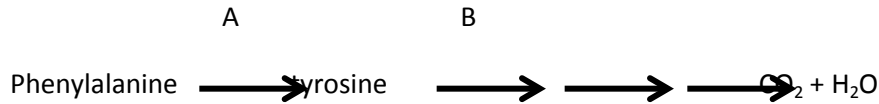

A person with PKU marries a person with AKU. What are the expected phenotypes for their children? Note: both diseases (PKU and AKU) are autosomal. Neither parent is heterozygous.

- a. All children will be ill
- b. All children will be normal
- c. Half of the children will have PKU, but the other half will be normal
- d. Half of the children will have AKU, but the other half will be normal

3. In frogs, formation of the eye lens is induced by chemical signals from

- a. cells that will become the neural plate
- b. cells that are forming the inner ear
- c. both cells that will become the neural plate and cells that are forming the inner ear
- d. both cells that will become the neural plate and an outgrowth of the developing brain

4. The diagram below is of a chromosome. Identify the pair of genes that would be most likely to be inherited together?

- a. A and B
- b. A and C
- c. A and D
- d. A and E

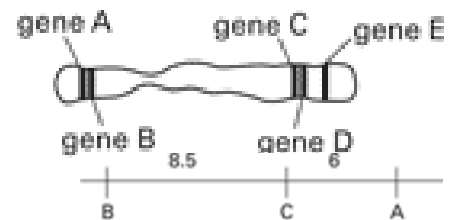

5. The gene linkage map shown in the figure below shows the order of genes A, B, and C. Which one of the following statements about the genes is true?

synthesized using mRNA as a template

Refer to the codon table for question # 13

Below is a small stretch of mRNA that would be translated at the ribosome:

...AUG CUG AAA UCA GGG...

13. Suppose a spontaneous mutation altered the underlined A, and changed it to a U. What effect, if any, would this have on the protein formed?

- a. Because of redundancy in the code, there would be no change in the protein formed.
- b. The amino acid sequence formed for this stretch of RNA would be Met-Leu-Lys-Ser-Gly.
- c. The polypeptide would not form because translation would stop at UAA.
- d. Translation would continue and a polypeptide would form because AUG codes for start as well as for methionine.

Questions 14-15 refer to the chart below.

A female fruit fly hybrid for both gray body (Gg) and normal wings (Nn) is crossed with a male with a black body (gg) and vestigial wings (nn): GgNn X ggnn.

The F1 results of the cross are shown in the chart below.

A	B	C	D
Gray normal	Black vestigial	Gray vestigial	Black normal
967	943	191	183

14. Which of the following statements best explains the results?

- The two alleles for body color and wing structure are located on separate chromosomes and assort independently.
- The two alleles for body color and wing structure are located on separate chromosomes and assort independently, but there was some crossing over.
- The two alleles are linked, located on the same chromosome, immediately next to one another, and inherited together.
- The two alleles are linked and located on the same chromosome but are far apart and experienced some crossing over.

15. Which of the following sketches depicts the most likely location of the alleles for body color and wing shape?

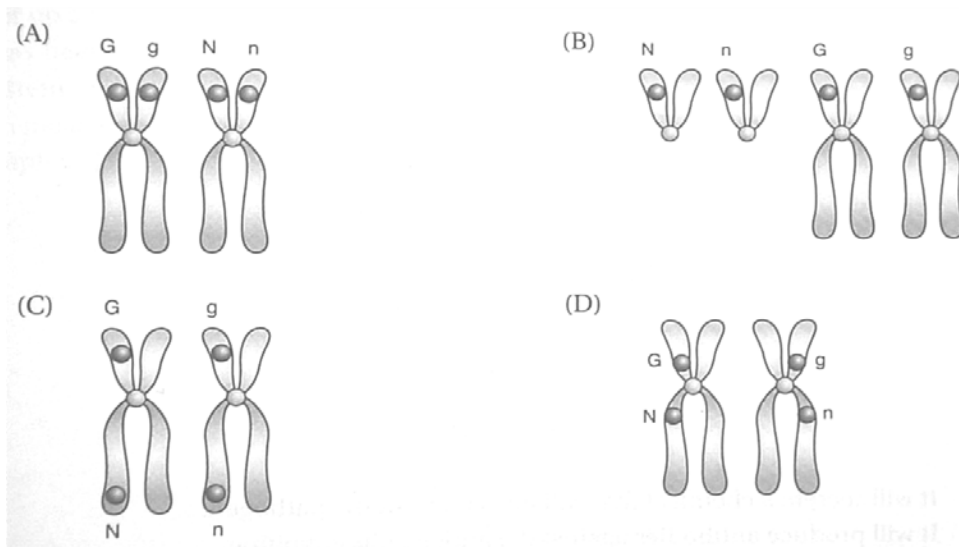

Questions 16-18 refer to the chart below.

Gregor Mendel's Pea Experiments: Results of Crosses			
P_1	F_1	F_2	F_2 Ratio
Smooth x Wrinkled Seeds	All Smooth	1,850 Smooth 474 Wrinkled	2.98:1
Yellow x Green Seeds	All Yellow	6,022 Yellow 2,001 Green	3.01:1
Axial x Terminal Flowers	All Axial	651 Axial 207 Terminal	3.14:1
Red x White Flowers	All Red	705 Red 224 White	3.15:1
Inflated x Constricted Pods	All Inflated	882 Inflated 299 Constricted	2.95:1
Green x Yellow Pods	All Green	428 Green 152 Yellow	2.82:1
Tall x Dwarf Plants	All Tall	787 Tall 277 Dwarf	2.84:1

16. Which of the following is **not** a valid conclusion that could be drawn from the results shown in the above table?

- a. The variations in the F2 generation's phenotypes show that the parental generation was not purebred.
- b. The F1 phenotypes indicate that the plants in the parental generation were all purebred.
- c. The F2 generation shows an approximate 3:1 ratio of the dominant to recessive trait.
- d. Tall plants with red flowers and yellow seeds have dominant traits.

17. According to the above table, how many traits did Mendel test?

- a. 2
- b. 3
- c. 7
- d. 8

18. According to the above table, what conclusion about the F1 generation can be drawn?

- a. There are two co-dominant alleles in the genes of all the F1 generation members.
- b. All the members of the F1 generation have a dominant and a recessive allele for each gene.
- c. The genes of the F1 generation members varied in terms of the number of dominant and recessive alleles.
- d. Not enough information is given to form a conclusion.

Questions 19-20 refer to the table below:

The table below shows the codons for six different amino acids as well as the STOP codon. Each amino acid is represented by its abbreviated name.

UUU Phe UUC	UAU Try UAC	UGU Cys UGC	GAA Glu GAG
UUA Leu UUG	CAU His CAC	UGA STOP UGG Trp	GUA Val GUG

19. A mutation caused the following change in an amino acid sequence : Phe-Leu-Cys-Trp-STOP changed to Phe-Leu-Phe-Trp-STOP. Based on the table, which of the following explains the mutation that occurred.

- a. UGU mutated to UUG b. UGU mutated to UGG c. UCG mutated to UUA d. UGU mutated to UUU

20. In the disease sickle-cell anemia, a point mutation causes the amino acid Glu to be replaced by Val. This forms a deformed red blood cell that results in debilitating symptoms.

Based on the data in the table, which of the following is a possible mutation that could result in this disease?

- a. GAA → GUA b. GUA → GAA c. GUG → GAG d. GAA → GAG

21. A karyotype is shown in the diagram to the right.

Information in this karyotype indicates

that the individual is a

- a. Female with sickle-cell
b. Female with down syndrome
c. male with phenylketonuria
d. male with Tay-Sachs disease

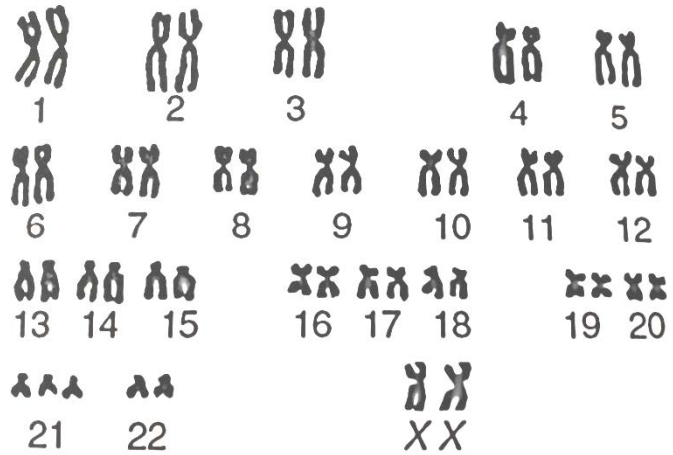

22. Identify the genes located on the q arm of chromosome 17.

- a. gastrin and GH1
- b. MPO and GLUT4
- c. BLMH and RP13
- d. RP13 and GLUT4
- e. TP53 and KRTHA1

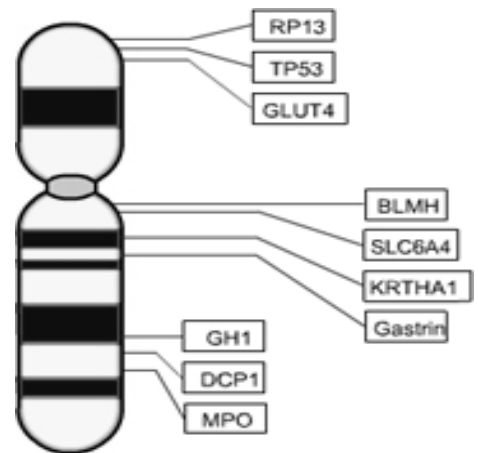

23. The formation of the fertilization membrane requires an increase in the availability of

- a. bicarbonate ions
- b. calcium ions
- c. hydrogen ions
- d. potassium ions.

24. The technique shown in the diagram below represents

- a. amniocentesis
- b. animal cloning
- c. the formation of recombinant DNA
- d. the formation of a karyotype

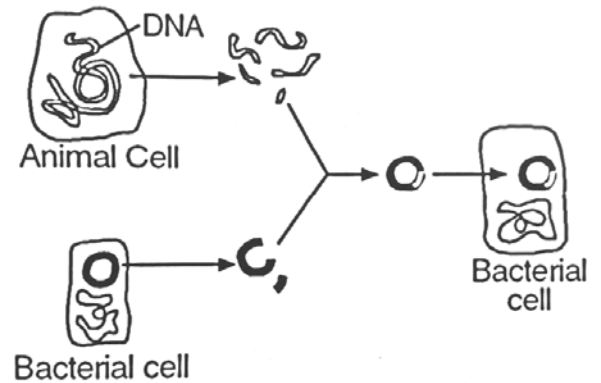

25. Which of the following is **NOT A DIFFERENCE** between transcription in prokaryotes and transcription in eukaryotes?

- a. The binding of RNA polymerase to DNA requires transcription factors in eukaryote and not in prokaryotes
- b. The elongation of the RNA molecule occurs in the 5',3' direction in prokaryotes
- c. There are more variations of the promoters in eukaryotic transcription than in prokaryotic transcription
- d. There are more RNA polymerases in eukaryotic transcription than in prokaryotic transcription

26. The presence of only one X-chromosome in each body cell of a human female produces a condition known as Turner's syndrome. This condition most probably results from

- a. hybridization b. nondisjunction
- c. crossing-over d. polyploidy

27. In the picture to the right, what process is depicted at #1?

- a. translation
- b. replication
- c. transcription
- d. mitosis

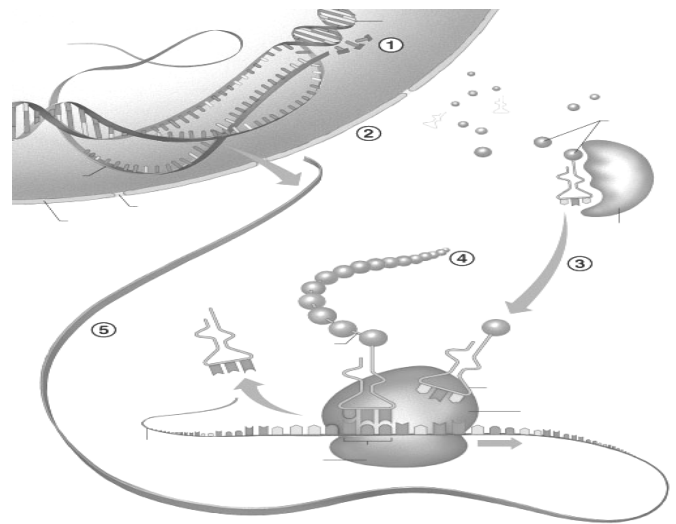

28. In the same picture, what is the best label for structure #5?

- a. single-stranded DNA
- b. messenger RNA
- c. transfer RNA
- d. amino acid chain

29. What type of error does the diagram below show?

- a. Point mutation
- b. Frame shift
- c. Nondisjunction
- d. Deletion



30. Hemophilia is due to a recessive allele on the X chromosome. What is the probable ratio of offspring from a cross between parents who have normal clotting, but the mother is a carrier.

- a. 50% chance any son will have hemophilia
- b. 100 % chance that any son will have hemophilia
- c. 50% chance that any daughter will have hemophilia
- d. 100 % chance that any daughter will have hemophilia.

31. Before the human genome project was sequenced by the Human Genome Project, scientists expected that they would find about 100,000 genes. In fact, they discovered that humans have only about 24,000 genes. How can we exhibit so many different traits from so few genes?

- a. modifications of histone proteins usually increases the function of genes
- b. epigenetics enables one gene to produce many different traits
- c. This is proof that pseudogenes and introns are expressed
- d. a single gene can produce only one trait.

Questions 32-35 refer to the list below of primary germ cells.

- a. Ectoderm
- b. Endoderm
- c. Mesoderm

32. Gives rise to the lining of the digestive tract

33. Gives rise to the brain and eyes

34. Gives rise to the blood

35. Gives rise to the bone

36. From earliest to latest, the overall sequence of early development proceeds in which of the following sequences?

a. first cell division → synthesis of embryo's DNA begins → acrosomal reaction → cortical reaction

b. cortical reaction → synthesis of embryo's DNA begins → acrosomal reaction → first cell division

c. cortical reaction → acrosomal reaction → first cell division → synthesis of embryo's DNA begins

d. acrosomal reaction → cortical reaction → synthesis of embryo's DNA begins → first cell division

37. During fertilization, the acrosomal contents

a. block polyspermy

b. help propel more sperm toward the egg

c. digest the protective jelly coat on the surface of the egg

d. nourish the mitochondria of the sperm

38. A scientist is studying a fish population and determines that there is one gene for eye-colour which has two alleles: *R* and *W*. She mates a red-eyed fish (*RR*) with a white-eyed fish (*WW*), and all of the F1 offspring have pink eyes. She then mates the F1 offspring with each other. What are the expected ratios of the F2 population?

a. 50% *RR*-red, 50% *WW*-white

b. 50% *RW*-pink, 50% *RR*-red

c. 25% *RR*-red, 50% *RW*-pink, 25% *WW*-white

d. 50% *RR*-red, 25% *RW*-pink, 25% *WW*-white

e. 25% *RR*-red, 25% *RW*-pink, 50% *WW*-white

39. The pedigree below illustrates the occurrence of an extremely rare genetic disease in a family over three generations. Black shapes represent individuals with the disease; circles are females, squares are males.

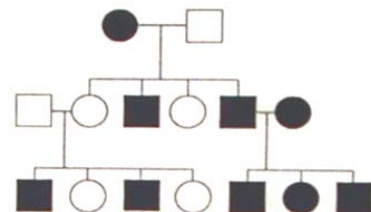

Based on this pedigree what type of allele is most likely the cause of this disease?

- a. X-linked recessive
- b. Y-linked recessive
- c. Autosomal dominant
- d. X-linked dominant

40. Mendel's law of segregation was substantiated by a general understanding of

- a. dominance
- b. meiosis
- c. mitosis
- d. pleiotropy
- e. epistasis

41. A molecular biologist would use a restriction enzyme (restriction endonuclease) for which of the following tasks?

- a. To excise a specific sequence from a genome for the creation of recombinant DNA.
- b. To discover which genes have been expressed in a cell by reverse-transcribing from mRNA.
- c. To join a specific sequence of DNA to a plasmid, creating a vector.
- d. To isolate a specific clone from a mixture of DNA.
- e. To denature the DNA double helix prior to replication in PCR (polymerase chain reaction).

42. DNA replication is considered a *semiconservative* process. What part of DNA is conserved during replication?

- a. The phosphodiester backbone of both strands of the DNA double helix is conserved, while the base pairs are replaced by their complements, A for T and C for G.
- b. After cellular division, one daughter cell contains all newly replicated DNA, while the other daughter cell contains the conserved parental DNA.
- c. In replication, purines (A and C) are replaced by their complementary pyrimidines (T and G), but the proportion of purines to pyrimidines is conserved.
- d. Only the sequence of the original parental DNA is conserved; the actual molecules of DNA are completely replaced by new base pairs and a new phosphodiester backbone.

- e. One strand of the original parental DNA acts as a template for replication, and is thus conserved as one strand in a new DNA double helix.

43. What would result from a mutation that results in two purines to pair with each other (or two pyrimidines to pair with each other)?

- a. The DNA helix would no longer have a constant diameter.
- b. Replication of DNA would stop because a 3' hydroxyl group would no longer be available.
- c. Ligase could no longer fulfill its function.
- d. Ribose would replace deoxyribose in the DNA's backbone.

44. Which statement best describes why DNA replication is referred to as "semi-conservative"?

- a. At each replication, each DNA molecule retains one strand intact and synthesizes the other strand from new material.
- b. After one round of replication, half of the DNA contains the original material and half is made up of new material.
- c. After two rounds of replication, all of the DNA contains a mixture of original and new material.
- d. Within each strand, the number of purines equals the number of pyrimidine.
- e. During replication, one strand acts as "leading" and the other as "lagging."

45. Which statement about genetic disorders in humans is **FALSE**?

- a. The frequency of the allele for sickle cell anemia is higher in native populations of wet, tropical countries because carriers have a better chance of surviving malaria.

- b. Colour blindness is rare in females because the condition is recessively inherited and the gene is sex linked.
- c. Down syndrome occurs when three copies of chromosome 21 are present.
- d. Aneuploidies, such as Down syndrome, results from errors in DNA replication during the S phase.
- e. Sperm containing a Y chromosome fertilizing an ovum (egg) that contains no sex chromosome results in a spontaneous abortion.

46. Fertilization normally

- a. reinstates diploidy
- b. follows gastrulation
- c. is required for parthenogenesis
- d. merges two diploid cells into one haploid cell.

47. The sticky end of the DNA restriction fragment shown here will pair with a DNA restriction fragment with the sticky end _____.

- a. ACGT
- b. AAAA
- c. ACGU
- d. GTAC
- e. TGCA

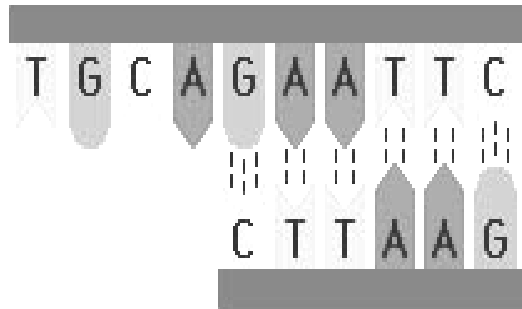

48. Which picture shows correct base-pairing?

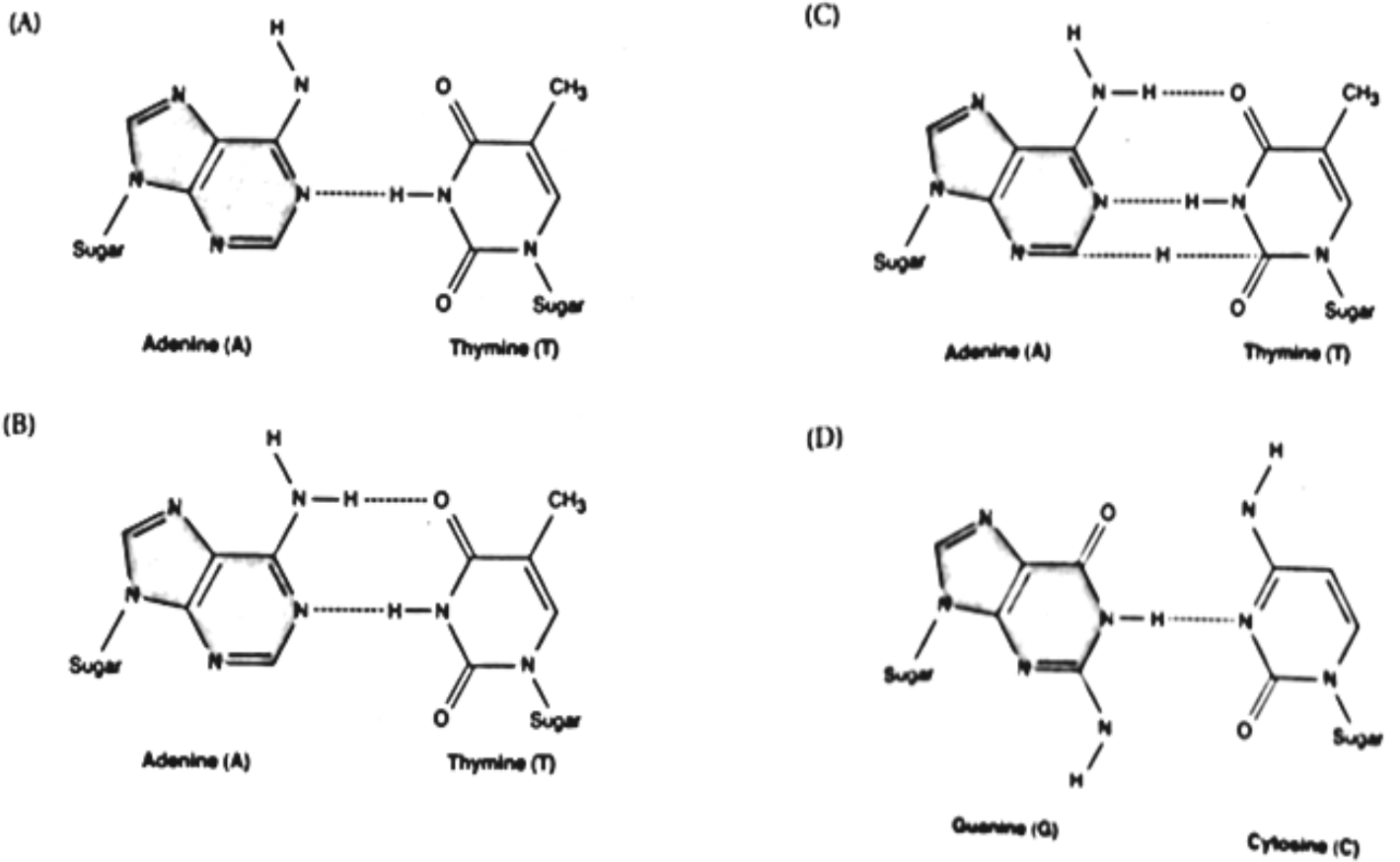

49. When DNA replicates, each strand of the original DNA molecule is used as a template for the synthesis of a second, complementary strand. Which of the following sketches most accurately illustrates the synthesis of a new DNA strand at the replication fork?

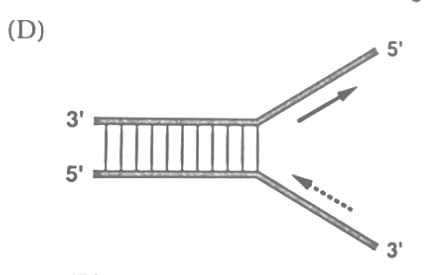
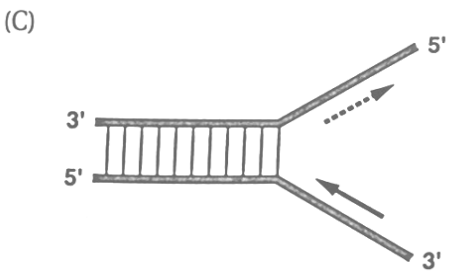
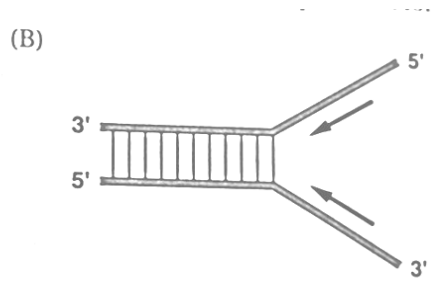
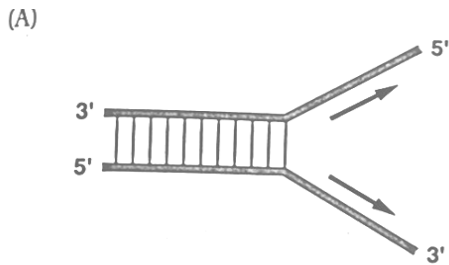

Questions 50-54 refer to the list below of inherited diseases.

- a. Phenylketonuria b. cystic fibrosis c. Huntington's disease d. hemophilia e. Down syndrome

- 50. Results from nondisjunction
- 51. Characterized by a buildup of fluid in the lungs
- 52. Autosomal dominant disease of the nervous system that results in death
- 53. Sex-linked disorder
- 54. Onset is usually in middle age

Use the following schematic to answer question 55-57. The fingerprint shows the results in a paternity dispute. DNA fragments in A represent the father, B represents the mother and C and D are the children.

- 55. Based on the fingerprint shown which of the following is correct?
 - a. Child C is an offspring of Parents A and B
 - b. Child D is an offspring of Parents A and B
 - c. Choices a and b are both correct
 - d. Neither child c nor d is genetically related to parents A and B

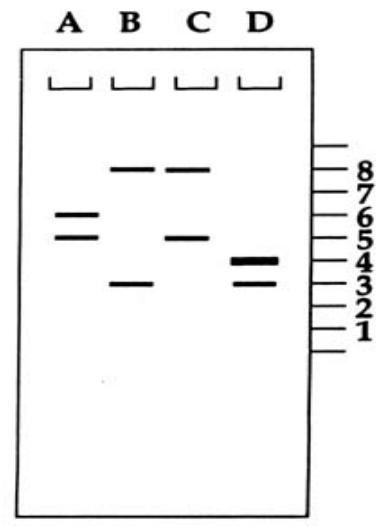

56. From where could the DNA samples used in this experiment have been taken?

- a. blood b. semen c. hair
- d. skin cell e. any of the above.

57. What process was used to make this DNA fingerprint?

- a. centrifugation b. electrophoresis c. bioassay
- d. vivisection e. distillation

Question 58 refers to the hypothetical pedigree of an inherited trait.

58. Select the true statement about the shaded in trait in the diagram on the lower right.

- a. the trait is autosomal recessive
- b. the trait is autosomal dominant
- c. the trait is sex-linked dominant
- d. the trait is sex-linked dominant
- e. the trait is inherited as incomplete dominance

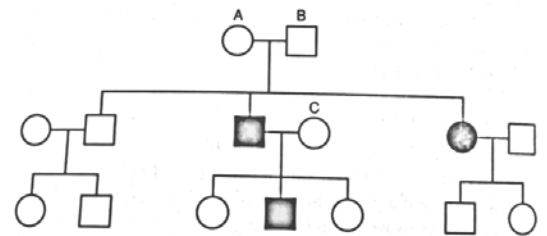

59. Which of the following experimental techniques involves treating a genetic disorder by replacing a defective gene with a functional gene?

- a. genetic screening c. genomics
- b. bioinformatics d. gene therapy

60. The following questions refer to the pedigree to the right for a family, some of whose members exhibit the dominant trait, *W*. Affected individuals are indicated by a dark square or circle. What is the likelihood that the progeny of IV-3 and IV-4 will have the trait?

- a. 0% b. 25% c. 50% d. 75%

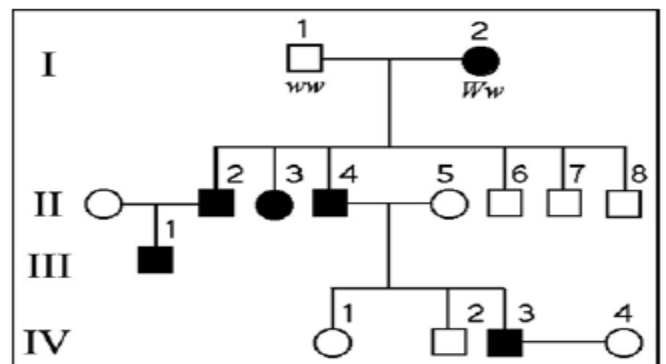

New Jersey Science League Blue Test

Biology I Answer Key

Date: February 13, 2014 (corrected)

1	B	16	A	31	B	46	A
2	B	17	A(C)	32	B	47	A
3	D	18	B	33	A	48	B
4	A	19	D	34	C	49	C
5	A	20	A	35	C	50	E
6	C	21	B	36	D	51	B
7	C	22	A	37	C	52	C
8	B	23	B	38	C	53	D
9	C	24	C	39	A	54	C
10	B	25	B	40	B	55	A
11	A	26	B	41	A	56	E
12	D	27	C	42	E	57	B
13	C	28	B	43	A	58	A
14	D	29	B	44	A	59	D
15	C	30	A	45	D	60	C

New Jersey Science League Biology I

March 13, 2014

Choose the answer that best completes the statements or questions below and fill in the appropriate response on the form. If you change an answer, be sure to completely erase your first choice. Please PRINT your name, school, area, and which test you are taking onto the scan-tron.

1. What evidence for a past evolutionary relationship can be seen in different groups of vertebrates?

- a. different features in early stages of embryos
- b. totally different protein sequences
- c. similar features in early stages of embryos
- d. no homologous structures in their anatomy

2. The DNA sequences of whales and ungulates, or hooved animals, are very similar. What type of evidence of evolution is this?

- a. vestigial
- b. molecular

c. embryological

d. fossil

3. As is true of the gametophytes of all land plants, the gametophytes of true mosses lack stomata. Yet, the feather moss *Pleurozium* harbors nitrogen-fixing cyanobacteria. Which of the following is a feature of moss gametophytes that is most important for the continued survival of these cyanobacteria in the tissues of the feather moss gametophyte?

- a. lack of cuticle
- b. lack of vascular tissues
- c. lack of true leaves or roots
- d. lack of an independent sporophyte
- e. lack of multiple cell layers in "leaves" of "buds"

4. In the Galápagos Islands, Charles Darwin saw different species of finch on different islands. This led him to theorize that species

- a. create their own environment.
- b. can adapt to their environment.
- c. choose their best environment.
- d. are found in many environments

5. Dog breeds, such as beagles, border collies, and German shepherds, were produced by the process of

- a. natural selection.
- b. artificial selection.
- c. descent without modification.
- d. inheritance of acquired characteristics.

	DERIVED TRAITS		
ORGANISMS	Vascular Tissue	Seeds	Flowers
<i>(M) mosses</i>	0	0	0

<i>(P) pine trees</i>	1	1	0
<i>(T) tulips</i>	1	1	1
<i>(B) bracken ferns</i>	1	0	0
TOTAL	3	2	1

Use the table above to answer questions 6- 8.

6. Which cladogram best represents the data?

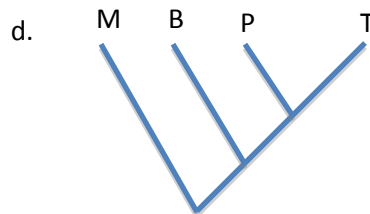
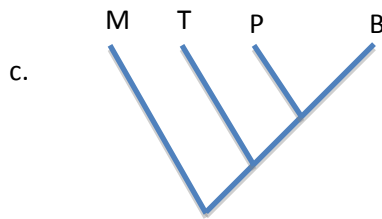
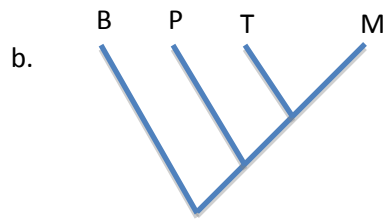
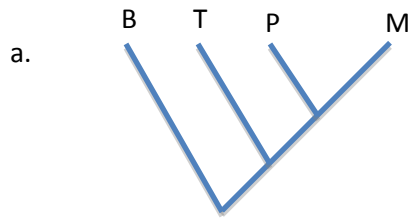

7. Potential changes in the relationships indicated will most probably come from

- DNA sequence analyses of extant (living) species.
- more-detailed analyses of the morphologies of extant species.
- the discovery of more fossils of extinct taxa from the time of seed-plant origins.
- more-detailed analyses of the life cycles of extant species.
- analyses of the types and structures of photosynthetic pigments present in extant species.

8. Distinguishing between pine trees and tulips seems to rest upon

- the types of conducting tissues that are present
- the types of photosynthetic pigments that are present
- the details of reproduction
- the concentration of stomata present on leaves of the saprophyte generation
- whether it is the sporophyte generation or the gametophyte generation that is dominant

9. The figure to the right below shows the change in a cactus population under pressure from peccaries (wild pigs) and parasitic insects. The dashed line shows the original cactus population. What type of selection does the graph show?

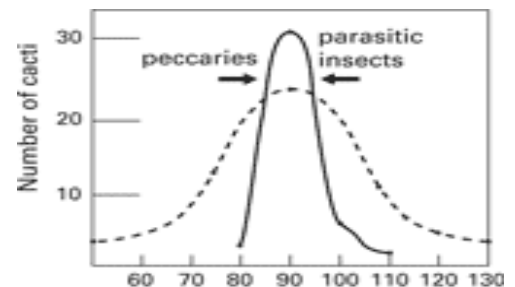

- a. directional
- b. stabilizing
- c. intermediate
- d. disruptive

10. A tsunami has destroyed almost all of the palm trees in an area. This event will most likely lead to

- a. gene flow following disruptive selection.
- b. microevolution by reproductive isolation.
- c. genetic drift through the bottleneck effect.
- d. speciation triggered by the founder effect.

11. What occurs when some elephants in a population migrate into another area and join another population?

- a. genetic drift
- b. microevolution
- c. speciation
- d. gene flow

12. For a certain population, the actual frequencies of a genotype did not match the genotype frequencies predicted by the Hardy-Weinberg equation. What can be said about the population?

- a. Allele frequencies are declining.
- b. The population is evolving.
- c. No mutations are occurring.
- d. Gene flow does not occur.

13. In a population of rattlesnakes that is evolving, which of the following statements is most likely true?

- a. The rates of gene flow and mutation are high.
- b. The population is in Hardy-Weinberg equilibrium.
- c. Directional selection is probably not occurring.
- d. Natural selection has no effect on this population.

14. During a study session about evolution, one of your fellow students remarks, "The giraffe stretched its neck while reaching for higher leaves; its offspring inherited longer necks as a result." Which statement is most likely to be helpful in correcting this student's misconception?

- a. Characteristics acquired during an organism's life are generally not passed on through genes.
- b. Spontaneous mutations can result in the appearance of new traits.
- c. Only favorable adaptations have survival value.
- d. Disuse of an organ may lead to its eventual disappearance.

15. Which of these conditions should completely prevent the occurrence of natural selection in a population over time?

- a. All variation between individuals is due only to environmental factors.
- b. The environment is changing at a relatively slow rate.
- c. The population size is large.
- d. The population lives in a habitat where there are no competing species present.

16. Given a population that contains genetic variation, what is the correct sequence of the following events, under the influence of natural selection?

1. Well-adapted individuals leave more offspring than do poorly adapted individuals.
 2. A change occurs in the environment.
 3. Genetic frequencies within the population change.
 4. Poorly adapted individuals have decreased survivorship.
- a. 2 → 4 → 1 → 3
 - b. 4 → 2 → 1 → 3
 - c. 4 → 1 → 2 → 3
 - d. 4 → 2 → 3 → 1

17. The larvae of some insects are merely small versions of the adult, whereas the larvae of other insects look completely different from adults, eat different foods, and may live in different habitats. Which of the following most directly favors the evolution of the latter, more radical, kind of metamorphosis?

- a. natural selection of sexually immature forms of insects
- b. changes in the homeobox genes governing embryonic development
- c. the evolution of meiosis
- d. the development of an oxidizing atmosphere on Earth
- e. the origin of a brain

18. Which of the following must exist in a population before natural selection can act upon that population?

- a. genetic variation among individuals
- b. variation among individuals caused by environmental factors
- c. sexual reproduction
- d. cross-species hybridization

19. Currently, two extant elephant species (X and Y) are placed in the genus *Loxodonta*, and a third species (Z) is placed in the genus *Elephas*. Thus, which statement should be true?

- a. Species X and Y are not related to species Z.
- b. Species X and Y share a greater number of homologies with each other than either does with species Z.
- c. Species X and Y share a common ancestor that is still extant (in other words, not yet extinct).
- d. Species X, Y, and Z share a common ancestor, but nothing more can be claimed than this.

20. The rise of methicillin-resistant *Staphylococcus aureus* (MRSA) can be considered to be an example of artificial selection because

- a. humans purposefully raise MRSA in large fermenters in an attempt to make the bacteria ever-more resistant.
- b. *S. aureus* is cultivated by humans to replenish the soil with nutrients.
- c. humans synthesize methicillin and create environments in which bacteria frequently come into contact with methicillin.
- d. Humans are becoming resistant to bacteria by taking methicillin.

21. DDT was once considered a "silver bullet" that would permanently eradicate insect pests. Today, instead, DDT is largely useless against many insects. Which of these would have been required for this pest eradication effort to be successful in the long run?

- a. Larger doses of DDT should have been applied.
- b. All habitats should have received applications of DDT at about the same time.
- c. The frequency of DDT application should have been higher.
- d. None of the individual insects should have possessed genes that made them resistant to DDT.

22. If the bacterium *Staphylococcus aureus* experiences a cost for maintaining one or more antibiotic-resistance genes, then what should happen in environments from which antibiotics are missing?

- a. These genes should continue to be maintained in case the antibiotics ever appear.
- b. These bacteria should be outcompeted and replaced by bacteria that have lost these genes.
- c. The bacteria should try to make the cost worthwhile by locating, and migrating to, microenvironments where traces of antibiotics are present.
- d. The bacteria should start making and secreting their own antibiotics.

23. Of the following anatomical structures, which is homologous to the bones in the wing of a bird?

- a. bones in the flipper of a whale
- b. cartilage in the dorsal fin of a shark
- c. bones in the hind limb of a kangaroo
- d. bony rays in the tail fin of a flying fish

24. Members of two different species possess a similar-looking structure that they use in a similar fashion to perform the same function. Which information would best help distinguish between an explanation based on homology versus one based on convergent evolution?

- a. The two species live at great distance from each other.
- b. The two species share many proteins in common, and the nucleotide sequences that code for these proteins are almost identical.
- c. The sizes of the structures in adult members of both species are similar in size.
- d. Both species are well adapted to their particular environments.

25. Both ancestral birds and ancestral mammals shared a common ancestor that was terrestrial. Today, penguins (which are birds) and seals (which are mammals) have forelimbs adapted for swimming. What term best describes the relationship of the bones in the forelimbs of penguins and seals, and what term best describes the flippers of penguins and seals?

- a. homologous; homologous
- b. analogous; homologous
- c. homologous; analogous
- d. analogous; analogous

26. In individual insects of some species, whole chromosomes that carry larval genes are eliminated from the genomes of somatic cells at the time of metamorphosis. A consequence of this occurrence is that

- a. we could not clone a larva from the somatic cells of such an adult insect.
- b. such species must reproduce only asexually.
- c. the descendants of these adults do not include a larval stage.
- d. metamorphosis can no longer occur among the descendants of such adults.

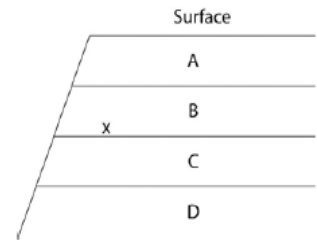

27-28. The following questions refer to the diagram to the right, which shows an outcrop of sedimentary rock whose strata are labeled A–D. The rock strata has not been over turned.

27. If *x* indicates the location of fossils of two closely related species, then fossils of their most-recent common ancestor are most likely to occur in which stratum?

- a. A
- b. B
- c. C
- d. D

28. One of the main issues with the fossil record is that

- a. we lack fossils of human ancestors
- b. most organisms do not leave fossil evidence
- c. we have very few fossils from before the existence of dinosaurs
- d. we don't know how long ago the organism that left the fossil existed

29. Currently, two extant elephant species (*X* and *Y*) are placed in the genus *Loxodonta* and a third species (*Z*) is placed in the genus *Elephas*. Assuming this classification reflects evolutionary relatedness, which of the following is the most accurate phylogenetic tree?

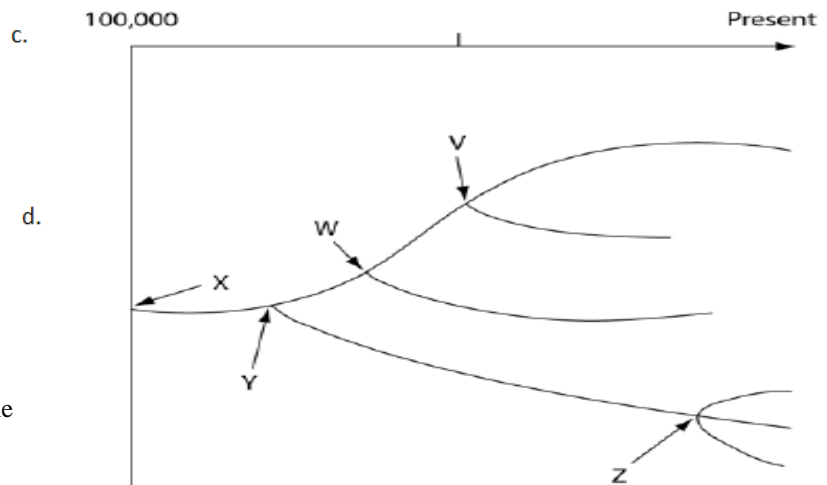
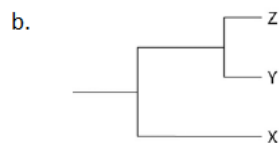
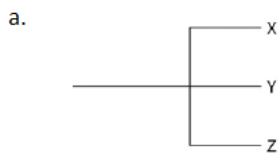

30-32. The following questions refer to the evolutionary tree below.

The horizontal axis of the cladogram depicted below is a timeline that extends from 100,000 years ago to the present; the vertical axis represents nothing in particular. The labeled branch points on the tree (V–Z) represent various common ancestors. Let's say that only since 50,000 years ago has there been enough variation between the lineages depicted here to separate them into distinct species, and only the tips of the lineages on this tree represent distinct species.

30. According to this evolutionary tree, what percent of the species seem to be extant (in other words, not extinct)?
a. 25% b. 33% c. 50% d. 66%

31. Which of the five common ancestors, labeled V–Z, has given rise to the greatest number of species, both extant and extinct?

- a. V
- b. W
- c. Z
- d. Both X and Y can be considered to have given rise to the greatest number of extant and extinct species.

32. Which of the five common ancestors, labeled V–Z, has been most successful in terms of the percent of its derived species that are extant?

- a. V
- b. W
- c. X
- d. z

Questions 33–34. About 13 different species of finches inhabit the Galápagos Islands today, all descendants of a common ancestor that arrived a few million years ago from the South American mainland. Genetically, there are four distinct lineages, but the 13 species are currently classified among three genera. The first lineage to diverge from the ancestral lineage was the warbler finch (genus *Certhidea*). Next to diverge was the vegetarian finch (genus *Camarhynchus*), followed by five tree finch species (also in genus *Camarhynchus*) and six ground finch species (genus *Geospiza*).

33. If the **six ground finch species** have evolved most recently, then which of these is the most logical prediction?

- a. They should be limited to the six islands that most recently emerged from the sea.
- b. Their genomes should be more similar to each other than are the genomes of the five tree finch species.
- c. They should share fewer anatomical homologies with each other than they share with the tree finches.
- d. The chances of hybridization between two ground finch species should be less than the chances of hybridization between two tree finch species.

34. A 14th species that descended from the original ancestral finch, the Cocos Island finch, is endemic to its namesake island, located 550 km off Costa Rica. The Cocos Island finch is genetically much more similar to the tree finches than is the vegetarian finch, yet it is classified in its own genus *Pinarolaxias*. Moreover, the Cocos Island finch and the vegetarian finch are the two finch species that are most genetically different from the ancestral Galápagos finch. Thus, if classification is to reflect evolutionary relationships, the vegetarian finch should

- a. remain in the genus *Camarhynchus*.
- b. be switched from *Camarhynchus* to *Certhidea*.
- c. be switched from *Camarhynchus* to *Pinarolaxias*.
- d. be placed in its own

35. Within six months of effectively using methicillin to treat *S. aureus* infections in a community, all new infections were caused by MRSA. How can this result best be explained?

- a. *S. aureus* can resist vaccines.
- b. A patient must have become infected with MRSA from another community.
- c. In response to the drug, *S. aureus* began making drug-resistant versions of the protein targeted by the drug.
- d. Some drug-resistant bacteria were present at the start of treatment, and natural selection increased their frequency.

36. DNA sequences in many human genes are very similar to the sequences of corresponding genes in chimpanzees. The most likely explanation for this result is that

- a. humans and chimpanzees share a relatively recent common ancestor.
- b. humans evolved from chimpanzees.

- c. chimpanzees evolved from humans.
- d. convergent evolution led to the DNA similarities.

37. You are confronted with a box of preserved grasshoppers of various species that are new to science and have not been described. Your assignment is to separate them into species. There is no accompanying information as to where or when they were collected. Which species concept will you have to use?

- a. biological
- b. phylogenetic
- c. ecological
- d. morphological

38. In a hypothetical situation, a certain species of flea feeds only on pronghorn antelopes. In rangelands of the western United States, pronghorns and cattle often associate with one another. If some of these fleas develop a strong preference for cattle blood and mate only with other fleas that prefer cattle blood, then over time which of these should occur, if the host mammal can be considered as the fleas' habitat?

- 1. reproductive isolation
- 2. sympatric speciation
- 3. habitat isolation
- 4. prezygotic barriers
- a. 1 only
- b. 2 and 3
- c. 1, 2, and 3
- d. 1 through 4

39. Chordate pharyngeal slits appear to have functioned first as

- a. the digestive system's opening.
- b. suspension-feeding devices.
- c. components of the jaw.
- d. gill slits for respiration.
- e. portions of the inner ear.

40. Among known plant species, which of these have been the *two* most commonly occurring phenomena that have led to the origin of new species?

- 1. allopatric speciation
- 2. sympatric speciation
- 3. sexual selection
- 4. polyploidy
- a. 1 and 3
- b. 1 and 4
- c. 2 and 3
- d. 2 and 4

41. According to the concept of punctuated equilibrium, the "sudden" appearance of a new species in the fossil record means that

- a. the species is now extinct.
- b. speciation occurred instantaneously.
- c. speciation occurred in one generation.
- d. speciation occurred rapidly in geologic time.

42-44. Questions 42, 43, 44 refer to the following evolutionary tree, whose horizontal axis represents time (present time is on the far right) and whose vertical axis represents morphological change.

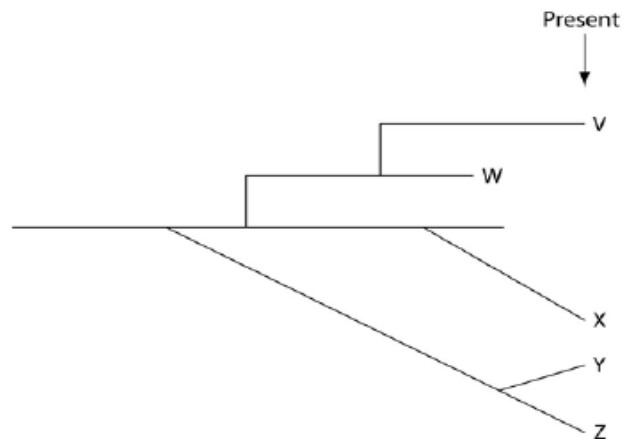

42. Which species is most closely related to species W?

- a. V is most closely related to species W.
- b. X is most closely related to species W.
- c. Y and Z are equally closely related to W.
- d. It is not possible to say from this tree

43. Which of the extant species originated earliest and appeared suddenly in the fossil record?

- a. V
- b. W
- c. X
- d. Y
- e. Z

44. Which conclusion can be drawn from this evolutionary tree?

- a. Gradualistic speciation and speciation involving punctuated equilibrium are mutually exclusive concepts; only one of them can occur.
- b. Eldredge and Gould would deny that the lineages labeled X, Y, and Z could represent true species.
- c. Assuming that the tip of each line represents a species, there are five extant (i.e., not extinct) species resulting from the earliest common ancestor.

d. A single clade (i.e., a group of species that share a common ancestor) can exhibit both gradualism and punctuated equilibrium.

45. In a hypothetical situation, the National Park Service, which administers Grand Canyon National Park in Arizona, builds a footbridge over the Colorado River at the bottom of the canyon. The footbridge permits interspersal of two closely related antelope squirrels. Previously, one type of squirrel had been restricted to the terrain south of the river, and the other type had been restricted to terrain on the north side of the river. Immediately before and ten years after the bridge's completion, researchers collected ten antelope squirrels from both sides of the river, took blood samples, and collected frequencies of alleles unique to the two types of antelope squirrels (see the following graphs).

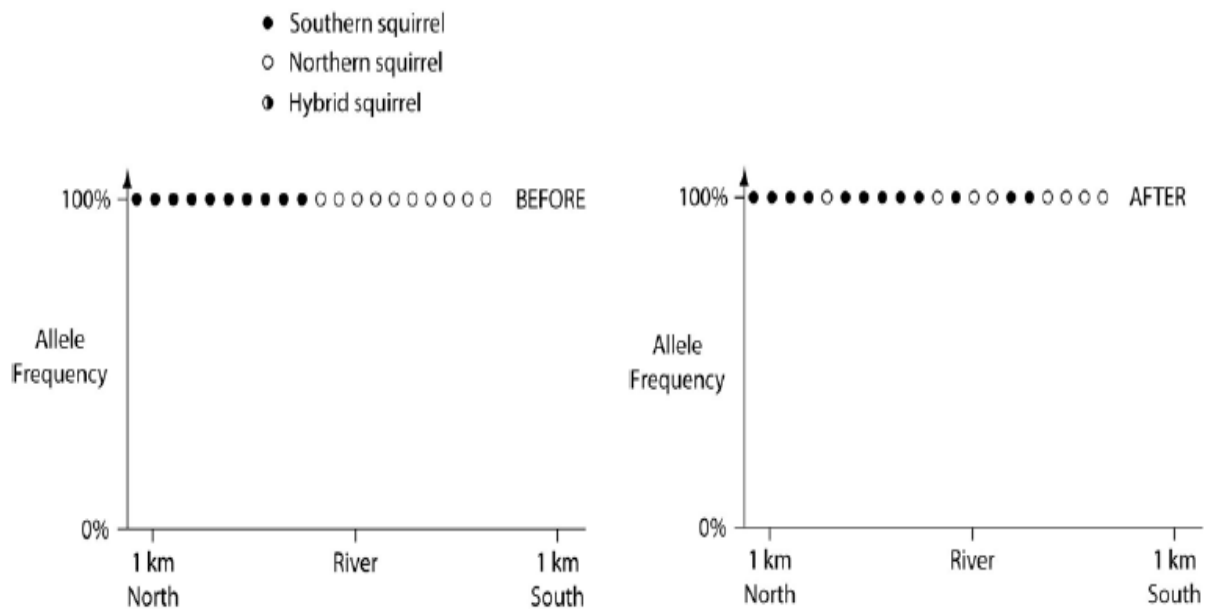

The data in the graphs above indicate that

- a hybrid zone was established after the completion of the bridge.
- no interspersal of the two types of squirrel occurred after the completion of the bridge.
- gene flow occurred from one type of squirrel into the gene pool of the other type of squirrel.
- two-way migration of squirrels occurred across the bridge, but without hybridization.

46. A new species of aquatic chordate is discovered that closely resembles an ancient form. It has the following characteristics: external armor of bony plates, no paired lateral fins, and a suspension-feeding mode of nutrition. In addition to these, it will probably have which of the following characteristics?

- legs
- no jaws
- an amniotic egg
- endothermy

Questions 47 and 48 refer to the following description.

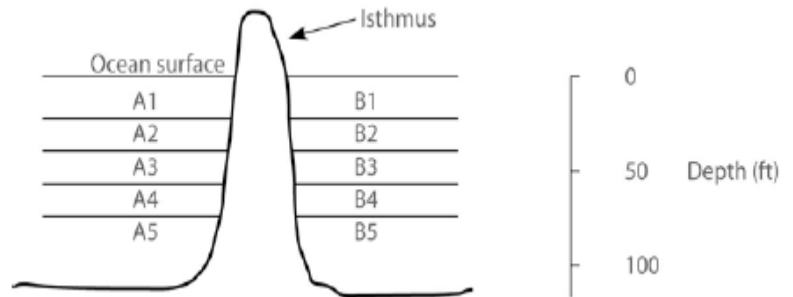

In the ocean, on either side of the Isthmus of Panama, are 30 species of snapping shrimp; some are shallow-water species, others are adapted to deep water. There are 15 species on the Pacific side and 15 different species on the Atlantic side. The Isthmus of Panama started rising about 10 million years ago.

In the following figure, the isthmus separates the Pacific Ocean on the left (side A) from the Atlantic Ocean on the right (side B). The seawater on either side of the isthmus is separated into five depth habitats (A1–A5), with A1 being the shallowest.

47. Which of these habitats is likely to harbor the youngest species?

- a. A5 b. B4 c. A3 d. A1

48. Which habitats should harbor snapping shrimp species with the greatest degree of genetic divergence from each other?

- a. A1 and A5 b. A4 and B5 c. B5 and B1 d. A5 and B5

49. Which of the following factors would *not* contribute to allopatric speciation?

- a. A population becomes geographically isolated from the parent population.
 b. The separated population is small, and genetic drift occurs.
 c. Gene flow between the two populations is extensive.
 d. Different mutations begin to distinguish the gene pools of the separated populations.

50. Which of the following statements best describes the effect of genetic drift on the gene frequencies of a population?

- a. Genes enter a population through immigration, thus changing gene frequencies.
 b. Genes leave a population through emigration, thus changing gene frequencies.
 c. Chance alone can cause significant changes in gene frequencies of small populations.
 d. Mutations over time cause gene frequencies to change.

51. Which of the following are necessary for evolution by natural selection to take place?

- i. Offspring resemble their parents more than other individuals in the population.
 ii. Differences among individuals exist and lead to different numbers of successful offspring being produced.
 iii. Individuals adjust their development depending on the environment.
 iv. Every individual has a desire to have many offspring.
 v. Populations tend to grow faster than their food supplies.

- a. i and ii
 b. i and v

- c. ii, iii, and iv
 d. iii and v

52. Which of the following would NOT generally affect allele frequencies in a population?

- a. Random mating c. Mutation
 b. Directional selection d. Emigration

53. Which of the following would generally reduce the likelihood of speciation?

- a. Geographical isolation
- b. Genetic variation in populations
- c. Natural selection
- d. Immigration and emigration

54. New strains of bacteria are becoming resistant to antibiotics at a high rate. Which genetic process is now responsible for most of this increase in the proportion of resistant bacteria?

- a. Transformation
- b. Transduction
- c. Mutation
- d. Insertion

55. What should be true of fossils of the earliest tetrapods?

- a. They should show evidence of internal fertilization.
- b. They should show evidence of having produced shelled eggs.
- c. They should indicate limited adaptation to life on land.
- d. They should be transitional forms with the fossils of chondrichthyans that lived at the same time.
- e. They should feature the earliest indications of the appearance of jaws.

56. Arrange these taxonomic terms from most inclusive (most general) to least inclusive (most specific).

1. lobe-fins 2. Amphibians 3. Gnathostomes 4. Osteichthyans 5. tetrapods

- a. 4, 3, 1, 5, 2
- b. 4, 3, 2, 5, 1
- c. 4, 2, 3, 5, 1
- d. 3, 4, 1, 5, 2
- e. 3, 4, 5, 1, 2

57. Which combination of characteristics in a population would provide the *greatest* potential for evolutionary change?

- a. small population, few mutations
- b. large population, few mutations
- c. small populations, many mutations
- d. large population, many mutations

58. Which term best describes the structures shown below?

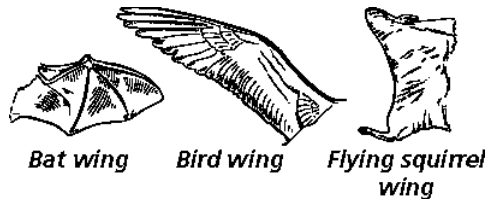

- a. homologous
- b. heterologous
- c. analogous
- d. vestigial

59. Which of the following is a correct statement about the relationship between natural selection and evolution?

- a. Natural selection results from evolution.
- b. Natural selection includes evolution as a part of it.
- c. Natural selection is one mechanism of evolution.
- d. Natural selection and evolution are the same thing.

60. When allelic frequencies remain unchanged, a population is in genetic equilibrium. This statement expresses which of the following?

- a. genetic drift
- b. Hardy-Weinberg principle
- c. sympatric speciation
- d. prezygotic isolating mechanism

New Jersey Science League Blue Test
Biology I Answer Key Date: March 13, 2014

1	C	16	A	31	D	46	B
2	B	17	B	32	D	47	D
3	E	18	A	33	B	48	D
4	B	19	B	34	D	49	C
5	B	20	C	35	D	50	C
6	D	21	D	36	A	51	A
7	A	22	B	37	D	52	A
8	C	23	A	38	D	53	D
9	B	24	B	39	B	54	A
10	C	25	C	40	D	55	C
11	D	26	A	41	D	56	D
12	B	27	C	42	A	57	C
13	A	28	B	43	B	58	C
14	A	29	D	44	D	59	C
15	A	30	D	45	D	60	B

NJSL Biology I Exam April 10, 2014

Choose the answer that best completes the statements or questions below and fill in the appropriate response on the form. If you change an answer, be sure to completely erase your first choice. Please PRINT your name, date of the exam, school, area, and which test you are taking onto the scan-tron.

1. Matter is sometimes gained or lost to an ecosystem, seemingly in violation of the law of conservation of matter. What is the reason for this seeming contradiction?

- A) Chemoautotrophic organisms can convert matter to energy.
- B) Matter can be moved in/out of an ecosystem from/to another ecosystem.
- C) Photosynthetic organisms convert solar energy to sugars.
- D) Detrivores convert matter to energy.
- E) Heterotrophs convert heat to energy.

2. To recycle nutrients, an ecosystem must have, at a minimum, **and**

- A) producers.
- B) producers and decomposers.
- C) producers, primary consumers, and decomposers.
- D) producers, primary consumers, secondary consumers, and decomposers.
- E) producers, primary consumers, secondary consumers, top carnivores, and decomposers.

3. Energy in an ecosystem is stored as:

- A) oxygen bonds
- B) organic molecules
- C) sunlight
- D) water
- E) sedimentary rock layers

4. What percentage of solar radiation striking a plant is converted into chemical energy?

- A) 1 to 10 %
- B) 10 to 20 %
- C) 20 to 50%
- D) 50 to 80%

5. Why is net primary production (NPP) a more useful measurement to an ecosystem ecologist than gross primary production (GPP)?

- A) NPP can be expressed in energy/unit of area/unit of time.
- B) NPP can be expressed in terms of carbon fixed by photosynthesis for an entire ecosystem.
- C) NPP represents the stored chemical energy that is available to consumers in the ecosystem.
- D) NPP is the same as the standing crop.
- E) NPP shows the rate at which the standing crop is utilized by consumers.

6. Aquatic ecosystems are least likely to be limited by which of the following nutrients?

- A) nitrogen
- B) carbon
- C) phosphorus
- D) iron
- E) zinc

7. How does inefficient transfer of energy among trophic levels result in the high endangerment status of many top-level predators?

- A) Top-level predators are destined to have small populations that are sparsely distributed.
- B) Predators have relatively large population sizes.
- C) Predators are more disease-prone than animals at lower trophic levels.
- D) Predators have short life spans and short reproductive periods.
- E) Top-level predators are more likely to be stricken with parasites.

8. Owls eat rats, mice, shrews, and small birds. Assume that, over a period of time, an owl consumes 5,000 J of animal material. Over the same period of time, the owl loses 2,300 J in feces and owl pellets and uses 2,500 J for cellular respiration. What is the primary efficiency of this owl?

- A) 0.02%
- B) 1%
- C) 4%
- D) 10%
- E) 40%

9. Why does a vegetarian leave a smaller ecological footprint than an omnivore?

- A) Fewer animals are slaughtered for human consumption.
- B) There is an excess of plant biomass in all terrestrial ecosystems.
- C) Vegetarians need to ingest less chemical energy than omnivores.
- D) Vegetarians require less protein than do omnivores.
- E) Eating meat is an inefficient way of acquiring photosynthetic productivity.

10. For most terrestrial ecosystems, pyramids of numbers, biomass, and energy are essentially the same—they have a broad base and a narrow top. The primary reason for this pattern is that

- A) secondary consumers and top carnivores require less energy than producers.
- B) at each step, energy is lost from the system as a result of keeping the organisms alive.
- C) as matter passes through ecosystems, some of it is lost to the environment.
- D) biomagnification of toxic materials limits the secondary consumers and top carnivores.

E) top carnivores and secondary consumers have a more general diet than primary producers.

11. Which of the following is primarily responsible for **limiting** the number of trophic levels in most ecosystems?

- A) Many primary and higher-order consumers are opportunistic feeders.
- B) Decomposers compete with higher-order consumers for nutrients and energy.
- C) Nutrient cycles involve both abiotic and biotic components of ecosystems.
- D) Nutrient cycling rates tend to be limited by decomposition.
- E) Energy transfer between trophic levels is in almost all cases less than 20% efficient.

12. Secondary consumers that can eat only primary consumers receive what percent of the energy fixed by primary producers in a typical field ecosystem?

- A) 0.1%
- B) 1%
- C) 10%
- D) 20%
- E) 80%

13. Consider the food chain: grass → grasshopper → mouse → snake → hawk. How much of the chemical energy fixed by photosynthesis of the grass (100%) is available to the hawk?

- A) 0.01%
- B) 0.1%
- C) 1%
- D) 10%
- E) 60%

14. Nitrogen is available to plants only in the form of

- A) Nitrogen(N_2) in the atmosphere.
- B) nitrite ions(NO_2^{-1}) in the soil.
- C) uric acid from animal excretions.
- D) amino acids from decomposing plant and animal proteins.
- E) nitrate ions(NO_3^{-1}) in the soil.

15. Which of the following locations is the reservoir for **nitrogen** in the nitrogen cycle?

- A) atmosphere
- B) sedimentary bedrock
- C) fossilized plant and animal remains (coal, oil, and natural gas)
- D) plant and animal biomass
- E) soil

16. Which of the following locations is the reservoir for **carbon** for the carbon cycle?

- A) atmosphere
- B) sediments and sedimentary rocks
- C) fossilized plant and animal remains (coal, oil, and natural gas)
- D) plant and animal biomass
- E) all of the above

17. How does phosphorus normally enter ecosystems?

- A) cellular respiration
- B) photosynthesis
- C) rock weathering
- D) vulcanism
- E) atmospheric phosphorous gas

18. In terms of nutrient cycling, why does timber harvesting in a temperate forest cause less ecological devastation than timber harvesting in tropical rain forests?

- A) Trees are generally less numerous in temperate forests, so fewer nutrients will be removed from the temperate forest ecosystem during a harvest.
- B) Temperate forest tree species require fewer nutrients to survive than their tropical counterpart species, so a harvest removes fewer nutrients from the temperate ecosystem.

- C) The higher temperatures in the tropics influence rain forest species to assimilate nutrients more slowly, so tropical nutrient absorption is much slower than in temperate forests.
- D) There are far fewer decomposers in tropical rain forests, so turning organic matter into usable nutrients is a slower process than in temperate forest ecosystems.
- E) Typical harvests remove up to 75% of the nutrients in the woody trunks of tropical rain forest trees, leaving nutrient-impoverished soils behind.

19. In a grassland community, which population has the smallest biomass?

- A) hawk
- B) snake
- C) shrew
- D) grasshopper
- E) grass

20. When levels of CO₂ are experimentally increased in a typical grassland community, C₃ plants generally respond with a greater increase in productivity than C₄ plants. This is because

- A) C₃ plants are more efficient in their use of CO₂.
- B) C₃ plants are able to obtain the same amount of CO₂ by keeping their stomata open for shorter periods of time.
- C) C₄ plants don't use CO₂ as their source of carbon.
- D) C₃ plants are more limited by CO₂ availability because they lack mechanisms to prevent transpirational water loss.
- E) C₃ plants have special adaptations for CO₂ uptake, such as larger stomata.

Use the following diagram of a food web to answer questions

21-23. In this **food web for a particular terrestrial ecosystem the arrows represent energy flow and letters represent species. Use the letters for the choices on questions # 21 and 22.**

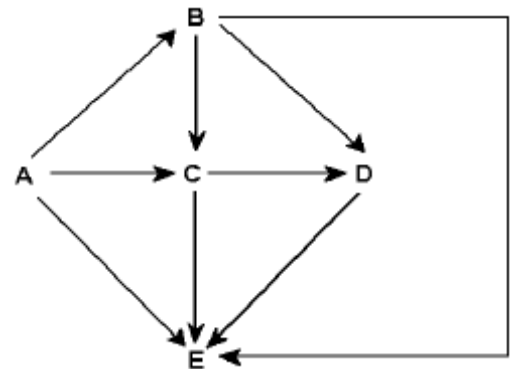

21. In this food web which species is autotrophic?

22. In this food web it is found that species C is toxic to predators. Which species is most likely to benefit from being a mimic of C?

23. In this food web which pair of species could be omnivores?

- A) A and B
- B) A and D
- C) B and C
- D) C and D
- E) C and E

For # 24 and 25 use the food web to the right. The arrows represent energy flow and letters represent species.

24. If the figure to the right represented a terrestrial food web, then the combined biomass of C + D would probably be

- A) greater than the biomass of A.
- B) less than the biomass of H.
- C) greater than the biomass of B.
- D) less than the biomass of A + B.
- E) less than the biomass of E.

25. In the figure above which letter represent phytoplankton?

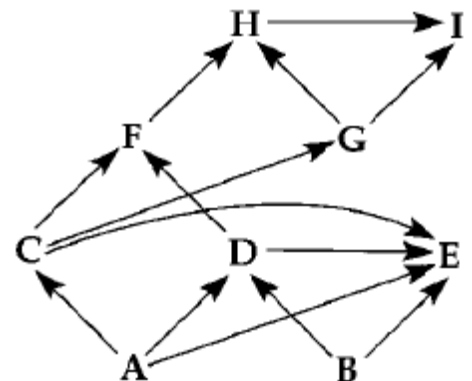

- A) A B) F C) C D) I E) E

Use the following diagram of the nitrogen cycle to complete questions 26-28.

26. Which number represents ammonium (NH_4^+)?

- A) 1 C) 3
B) 2 D) 4

27. Which number represents nitrogen-fixing bacteria?

- A) 5
B) 6
C) 7

28. Which number represents nitrifying bacteria?

- A) 5
B) 6
C) 7

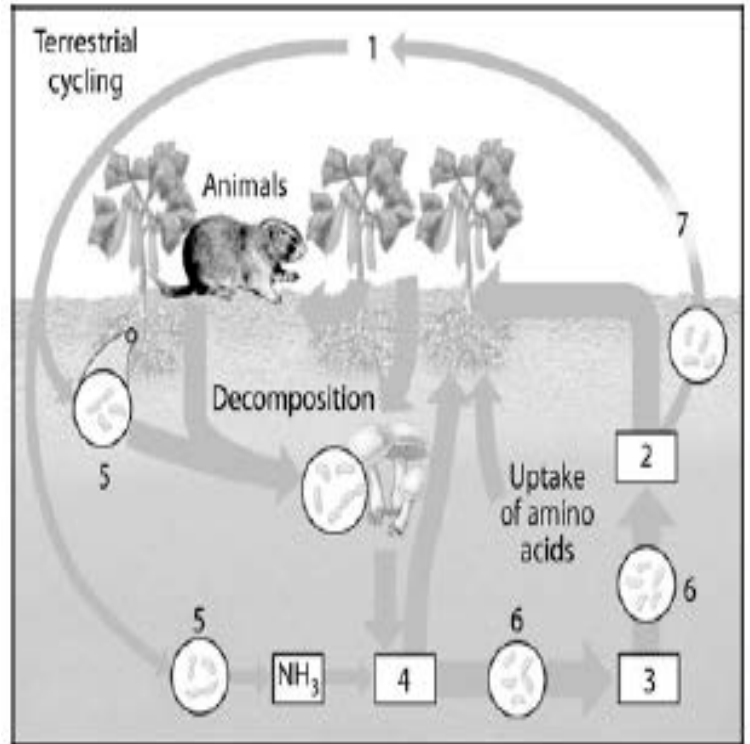

29. Suppose you are studying the nitrogen cycling in a pond ecosystem over the course of a month. While you are collecting data, a flock of 100 Canada geese lands and spends the night during a fall migration. What could you do to eliminate error in your study as a result of this event?

- A) Find out how much nitrogen is consumed in plant material by a Canada goose over about a 12-hour period, multiply this number by 100, and add that amount to the total nitrogen in the ecosystem.
B) Find out how much nitrogen is eliminated by a Canada goose over about a 12-hour period, multiply this number by 100, and subtract that amount from the total nitrogen in the ecosystem.
C) Find out how much nitrogen is consumed and eliminated by a Canada goose over about a 12-hour period and multiply this number by 100; enter this +/- value into the nitrogen budget of the ecosystem.
D) Do nothing. The Canada geese visitation to the lake would have negligible impact on the nitrogen budget of the pond.
E) Put a net over the pond so that no more migrating flocks can land on the pond and alter the nitrogen balance of the pond.

30. Nitrifying bacteria participate in the nitrogen cycle mainly by

- A) converting nitrogen gas to ammonia.
B) releasing ammonium from organic compounds, thus returning it to the soil.
C) converting ammonia to nitrogen gas, which returns to the atmosphere.
D) converting ammonium to nitrate, which plants absorb.
E) incorporating nitrogen into amino acids and organic compounds.

31. Which statement describes the functioning of photosystem II?

- A) Light energy excites electrons in the thylakoid membrane electron transport chain.
B) Photons are passed along to a reaction-center chlorophyll.
C) The P680 chlorophyll donates a pair of protons to NADP^+ , which is thus converted to NADPH.

- D) The electron vacancies in $P680^+$ are filled by electrons derived from water.
- E) The splitting of water yields molecular carbon dioxide as a by-product.

32. Which of the following are directly associated with photosystem I?

- A) harvesting of light energy by ATP
- B) receiving electrons from the thylakoid membrane electron transport chain
- C) generation of molecular oxygen
- D) extraction of hydrogen electrons from the splitting of water
- E) passing electrons to the thylakoid membrane electron transport chain

33. Assume a thylakoid is somehow punctured so that the interior of the thylakoid is no longer separated from the stroma. This damage will have the most direct effect on which of the following processes?

- A) the splitting of water
- B) the absorption of light energy by chlorophyll
- C) the flow of electrons from photosystem II to photosystem I
- D) the synthesis of ATP
- E) the reduction of $NADP^+$

34. What does the chemiosmotic process in chloroplasts involve?

- A) establishment of a proton gradient across the thylakoid membrane
- B) diffusion of electrons through the thylakoid membrane
- C) reduction of water to produce ATP energy
- D) movement of water by osmosis into the thylakoid space from the stroma
- E) formation of glucose, using carbon dioxide, NADPH, and ATP

35. Which of the following statements best describes the relationship between photosynthesis and respiration?

- A) Respiration runs the biochemical pathways of photosynthesis in reverse.
- B) Photosynthesis stores energy in complex organic molecules, whereas respiration releases it.
- C) Photosynthesis occurs only in plants and respiration occurs only in animals.
- D) ATP molecules are produced in photosynthesis and used up in respiration.
- E) Respiration is anabolic and photosynthesis is catabolic.

36. The reactions that produce molecular oxygen (O_2) take place in

- A) the light reactions alone.
- B) the Calvin cycle alone.
- C) both the light reactions and the Calvin cycle.
- D) neither the light reactions nor the Calvin cycle.
- E) the chloroplast, but are not part of photosynthesis.

37. A flask containing photosynthetic green algae and a control flask containing water with no algae are both placed under a bank of lights, which are set to cycle between 12 hours of light and 12 hours of dark. The dissolved oxygen concentrations in both flasks are monitored. Predict what the relative dissolved oxygen concentrations will be in the flask with algae compared to the control flask.

- A) The dissolved oxygen in the flask with algae will always be higher.
- B) The dissolved oxygen in the flask with algae will always be lower.
- C) The dissolved oxygen in the flask with algae will be higher in the light, but the same in the dark.
- D) The dissolved oxygen in the flask with algae will be higher in the light, but lower in the dark.
- E) The dissolved oxygen in the flask with algae will not be different from the control flask at any time.

38. Plants photosynthesize only in the light. Plants respire

- A) in the dark only.
- B) in the light only.
- C) both in light and dark.
- D) never—they get their ATP from photophosphorylation.
- E) only when excessive light energy induces photorespiration.

Use the following figure and the compounds labeled A, B, C, D, and E to answer questions 39-41.

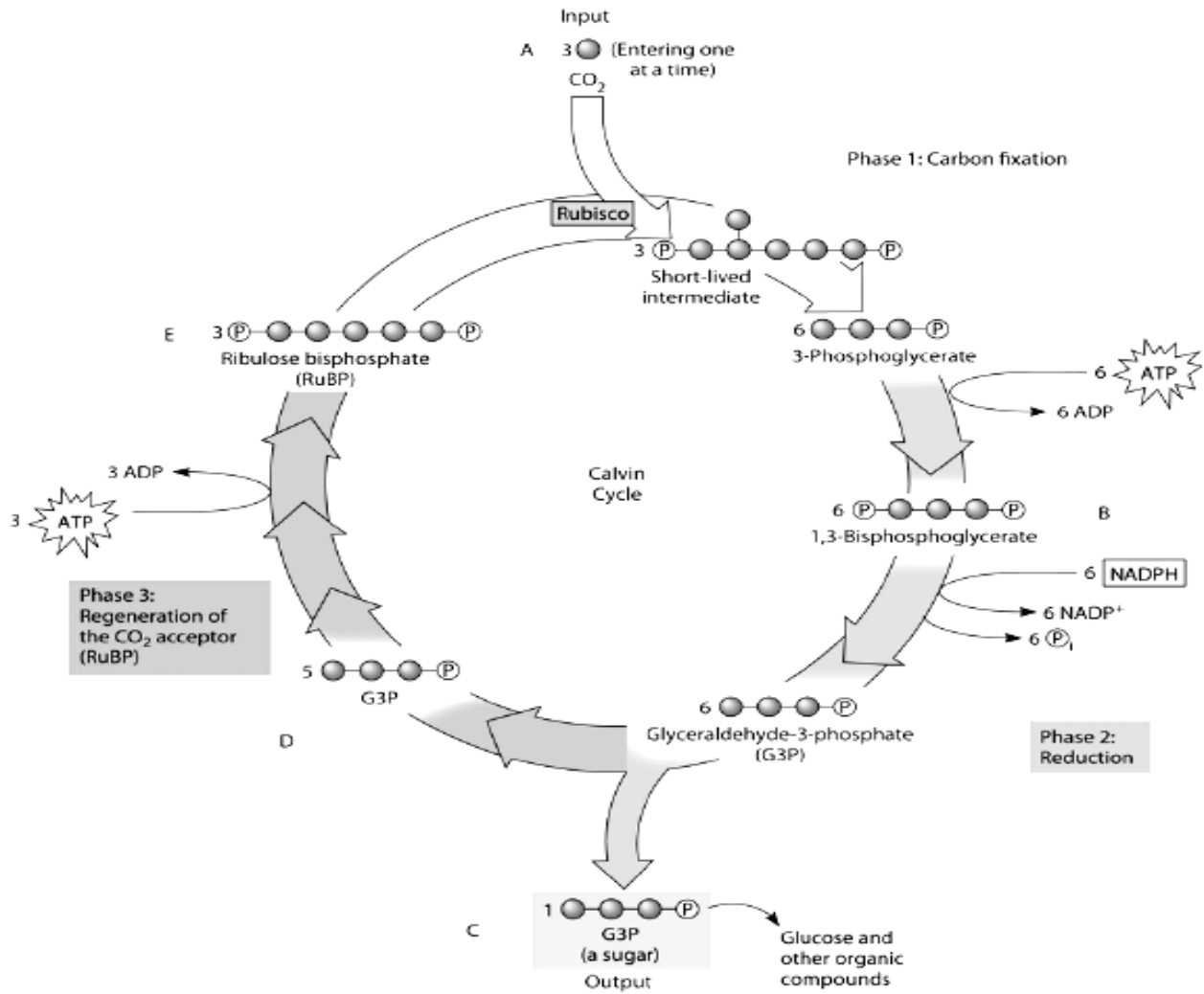

39. If ATP used by this plant is labeled with radioactive phosphorus, which molecule or molecules of the Calvin cycle will be radioactively labeled first?

- A) B only
- B) B and C only
- C) B, C, and D only
- D) B and E only
- E) B, C, D, and E

40. If the carbon atom of the incoming CO₂ molecule is labeled with a radioactive isotope of carbon, which organic molecules will be radioactively labeled after one cycle?

- A) C only
- B) B, C, D, and E
- C) C, D, and E only
- D) B and C only
- E) B and D only

41. Which molecule(s) of the Calvin cycle is (are) also found in glycolysis?

- A) B, C, E, and 3-phosphoglycerate
- B) B, C, and E only
- C) 3-phosphoglycerate only
- D) B, C, D, and 3-phosphoglycerate only
- E) E only

42. Why is the climate drier on the leeward side of mountain ranges that are subjected to prevailing winds?

- A) Deserts usually are found on the leeward side of mountain ranges.
- B) The sun illuminates the leeward side of mountain ranges at a more direct angle, converting to heat energy, which evaporates most of the water present.
- C) Pushed by the prevailing winds on the windward side, air is forced to rise, cool, condense, and drop its precipitation, leaving only dry air to descend the leeward side.
- D) Air masses pushed by the prevailing winds are stopped by mountain ranges and the moisture is used up in the stagnant air masses on the leeward side.
- E) More organisms live on the sheltered, leeward side of mountain ranges where their utilization of water lowers the amount available when compared to the windward side.

43. Which statement describes how climate might change, if the Earth was 75% land and 25% water?

- A) Terrestrial ecosystems would likely experience more precipitation.
- B) Earth's daytime temperatures would be higher and nighttime temperatures lower.
- C) Summers would be longer and winters shorter at mid-latitude locations.
- D) Earth would experience an unprecedented global warming.
- E) More terrestrial microclimates would be created because of daily fluctuations in climate.

44. Deserts typically occur in a band at 20 degrees north and south latitude because

- A) descending air masses tend to be cool and dry.
- B) trade winds have a little moisture.
- C) moisture-laden air is heavier than dry air and is not carried to these latitudes.
- D) ascending air tends to be moist.
- E) these locations get the most intense solar radiation of any location on Earth.

45. What is the limiting factor for the growth of trees in the tundra?

- A) low precipitation
- B) low temperatures
- C) insufficient minerals in bedrock
- D) pH of soils
- E) permafrost

46. Turnover of water in temperate lakes during the spring and fall is made possible by which of the following?

- A) warm, less dense water layered at the top
- B) cold, more dense water layered at the bottom
- C) a distinct thermocline between less dense warm water and cold, dense water
- D) the changes in the density of water as seasonal temperatures change
- E) currents generated by nektonic animals

47. The growing season would generally be shortest in which of the following biomes?

- A) savanna
- B) temperate broadleaf forest
- C) temperate grassland
- D) tropical rain forest
- E) boreal coniferous forest

Use the following figure to answer questions 48-51.

The eight climographs below show yearly temperature (line graph and left vertical axis) and precipitation (bar graph and right vertical axis) averages for each month for some locations on Earth. Choose the climograph that best answers the question or completes the statement. Climographs may be used once, more than once, or not at all.

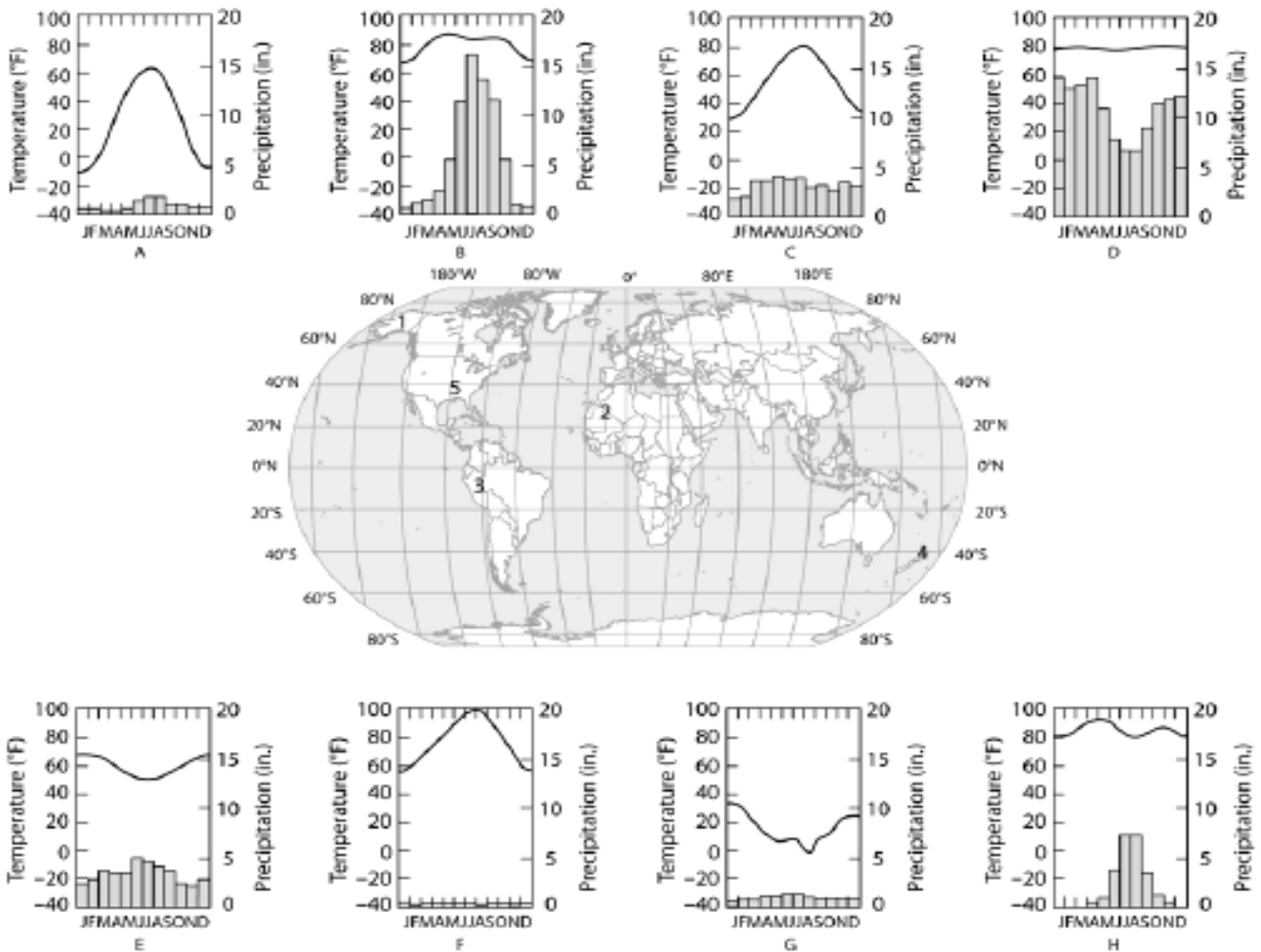

48. Which climograph shows the climate for location 2?

- A) B
- B) C
- C) D
- D) F

49. Which climograph shows the climate for location 3?

- A) B
- B) C
- C) D
- D) E

50. Which climograph shows the climate for location 4?

- A) A
- B) B
- C) C
- D) E
- E) G

51. Which of the following best substantiates why location 3 is an equatorial (tropical) climate?

- A) It has a monsoon season during the winter months.
- B) It has consistent monthly averages for rainfall.
- C) The temperature is high for each monthly average.
- D) The temperatures reach 100°F during some months.
- E) The temperatures are lower in June, July, and August.

52. Use this description to answer the following question. In areas of permafrost, stands of black spruce are frequently observed in the landscape, while other tree species are noticeably absent. Often these stands are referred to “drunken forests” because many of the black spruce are displaced from their normal vertical alignment. What might be the adaptive significance of these unusual forests growing the way they do in this marginal habitat?

- A) Needles are adapted to withstand cold arctic temperatures.
- B) Branches are adapted to absorb more CO₂ with this displaced alignment.
- C) Taproot formation is impossible, so trees developed shallow root beds.
- D) Trees are tilted so snow prevents them from breaking or tipping over.
- E) Trees tip so that they do not compete with each other for sunlight.

53. Which of the following biomes is correctly paired with the description of its climate?

- A) savanna—low temperature, precipitation uniform during the year
- B) tundra—long summers, mild winters
- C) temperate broadleaf forest—relatively short growing season, mild winters
- D) temperate grasslands—relatively warm winters, most rainfall in summer
- E) tropical forests—nearly constant day length and temperature

54. When climbing a mountain, we can observe transitions in biological communities that are analogous to the changes

- A) in biomes at different latitudes.
- B) at different depths in the ocean.
- C) in a community through different seasons
- D) in an ecosystem as it evolves over time.
- E) across the United States from east to west.

55. As you study two closely related predatory insect species, the two-spot and the three-spot avenger beetles, you notice that each species seeks prey at dawn in areas where the other is absent. However, where their ranges overlap, the two-spot avenger beetle hunts at night and the three-spot hunts in the morning. When you bring them into the laboratory and isolate the two different species, you discover that the offspring of both species are found to be nocturnal. You have discovered an example of

- A) mutualism.
- B) character displacement.
- C) Batesian mimicry.
- D) facultative commensalism.
- E) resource partitioning.

56. Prairie dogs once covered the expanses of the Great Plains. Their grazing made the grass more nutritious for the huge herds of bison, and they were preyed upon by a variety of snakes, raptors, and mammals. In fact, the black-footed ferret (now endangered) specialized in prairie dog predation. Today, increases in housing and agricultural developments have eradicated many prairie dog towns. Which of the following statements about prairie dogs is true?

- A) Their realized niche has expanded.
- B) They have a competitive relationship with bison.
- C) They are probably a poor candidate for keystone species.
- D) Their fundamental niche has been compromised.
- E) Their fundamental niche has expanded.

57. In a particular case of secondary succession, three species of wild grass all invaded a field. By the second season, a single species dominated the field. A possible factor in this secondary succession was

- A) equilibrium.
- B) facilitation.
- C) immigration.
- D) inhibition.
- E) parasitism.

58. Although extinction is a natural process, current extinctions are of concern to environmentalists because

- A) more animals than ever before are going extinct.
- B) most current extinctions are caused by introduced species.
- C) the rate of extinction is unusually high.
- D) current extinction is primarily affecting plant diversity.

59. Which of the following is the most direct threat to biodiversity?

- A) increased levels of atmospheric carbon dioxide
- B) the depletion of the ozone layer
- C) overexploitation of selected species
- D) habitat destruction
- E) zoned reserves

60. How is habitat fragmentation related to biodiversity loss?

- A) Less carbon dioxide is absorbed by plants in fragmented habitats.
- B) In fragmented habitats, more soil erosion takes place.
- C) Populations of organisms in fragments are smaller and, thus, more susceptible to extinction.
- D) Animals are forced out of smaller habitat fragments.
- E) Fragments generate silt that negatively affects sensitive river and stream organisms.

New Jersey Science League

Biology I Answer Key Blue Test

Date: April 10, 2014

Record onto the area record the # correct

1	B	16	E	31	D	46	D
2	B	17	C	32	B	47	E
3	B	18	E	33	D	48	D
4	A	19	A	34	A	49	C
5	C	20	A	35	B	50	D
6	B	21	A	36	A	51	C
7	A	22	B	37	D	52	C
8	C	23	E	38	C	53	E
9	E	24	D	39	D	54	A
10	B	25	A	40	B	55	E
11	E	26	D	41	D	56	D
12	B	27	A	42	C	57	D
13	A	28	B	43	B	58	C
14	E	29	C	44	A	59	D
15	A	30	D	45	E	60	C